



**panel**<sup>®</sup>  
system

**Installation  
Guide**

 **AL13** architectural  
systems

**01** **General Guidelines**

**02** **Pro Tips**

**03** **Standard Wall Installation**

**04** **Fascia Installation**

**05** **Fascia Installation - Alternate**

**06** **Protective Film Removal**

01

# General Guidelines

---

## General Guidelines

### IMPORTANT: Failure to follow the guidelines herein will void the AL13® warranty

Please read and understand this guide. Any questions or inconsistencies should be directed to [info@al13.com](mailto:info@al13.com).

Guidelines may vary depending on project particulars and conditions. Contact AL13® with questions regarding variance from this guide. Standard carpentry skills are required for optimum results.

Good health and safety practices must be followed when installing AL13® Panel System. Please refer to the AL13® Material Safety Data Sheets for more info.

---

### Key steps for a successful installation

- 01 Understand the various elements of the system
- 02 Plan the installation, work schedule, layout, and material usage
- 03 Ensure everyone working has read the installation guidelines
- 04 Execute work in the sequence set forth in the installation guidelines
- 05 Protection should be worn: gloves, ear protection, steel-toe boots, safety glasses and hard hat
- 06 Protect the product by storing the material in a dry and clean environment
- 07 Ensure proper fit of the system
- 08 Upon completion of installation, remove protective film and clean any debris on the wall

---

### Pre-installation: Receiving materials

When materials arrive on site, ensure that all panels, extrusions and other component packaging are in good condition, free of any defects, and verify that the materials match the order / shop drawings.

- > Shipping or packaging issues should be noted on the waybill and then reported to the distributor
- > Should any products be damaged, the receiving party is responsible for filling a freight claim to the shipping company within 24 hours of receiving product.
- > Defective materials should be reported to the distributor from which the product was dispatched.

---

## General Guidelines

### Inventory

Once material is verified to be in good condition, take inventory of units according to the packing slip. Make sure all materials - panel, extrusion, fasteners, and adhesive tape - and quantities are present.

*The distributor should be notified immediately if the order has any missing or incomplete components. Failure to do so may void re-fulfillment.*

---

### Material Handling

AL13® ACM System panels are shipped on pallets in fifty (50) sheets or fewer. The sheets are secured in place with metal strapping and covered with protective wrap. Panels should be kept in their original packaging or similar and moved by a forklift or pallet jack.

Once a pallet is unwrapped and metal straps are cut, panels may be moved individually. Ensure to use clean work gloves to protect from sharp edges and keep panels clean. Panels must be first lifted vertically away from the pallet, then away—**DO NOT DRAG OR SLIDE PANELS.**

Store all materials in a clean and dry environment, both before and after materials are unpacked

Wear gloves when handling materials, and use suction cups when mounting panels to the wall. Be sure to wear eye and ear protection when cutting materials. Always wear appropriate personal protective equipment.



---

### Tools









Our Panel System is made to be installed with general tools. A recommended tool list is as follows:

- > Sawhorses/work table
- > Circular saw, handheld with guide
- > Table saw
- > Cordless electric impact with appropriate bits
- > AL13 saw blades
- > AL13 SLED tool
- > AL13 suction cups
- > Jigsaw
- > File (for deburring cut sheets)
- > Level/plumb line
- > Chalk line
- > Cordless electric drill
- > Drill bit set

## Product Legend

Component	Size / piece	Material
 4mm ACM Panel	4' x 8' sheet	AAMA 2605 coated with FR core
 3mm Solid Plate	4' x 8' sheet	AAMA 2605 coated aluminum plate
 End Frame	8' length	AAMA 2605 coated aluminum extrusion
 Inside Corner	8' length	AAMA 2605 coated aluminum extrusion
 Outside Corner	8' length	AAMA 2605 coated aluminum extrusion
 Flat Cap: Perimeter	8' length	AAMA 2605 coated aluminum extrusion
 Flat Cap	8' length	AAMA 2605 coated aluminum extrusion
 Reveal Cap: Perimeter	8' length	AAMA 2605 coated aluminum extrusion
 Reveal Cap	8' length	AAMA 2605 coated aluminum extrusion
 Two Piece Outside Corner Cap	8' length	AAMA 2605 coated aluminum extrusion

## Product Legend

Component	Size / piece	Material
 Back Plate: Universal	8' length	Black powder coated aluminum extrusion
 Back Plate: Extended	8' length	Black powder coated aluminum extrusion
 Two-Piece Outside Corner Back Plate	8' length	Black powder coated aluminum extrusion
 I-Beam	8' length	Aluminum extrusion
 System Clip: Compressible	Package of 100ea	Glass-filled polyamide
 Wood Fastener	500/package 1-1/2in long	Wood Substrate: #12-14 x 1 1/2" mini drill-point fasteners with EPDM washers and corrosion-resistant coating
 Concrete Fastener	100/package 1-1/4in long	Concrete walls: #11 x 1 1/4" concrete screw anchor with corrosion-resistant coating
 Metal Fastener	500/package 3/4in long	Steel substrate: #10-16 x 3/4" self-drilling, self-tapping screws with corrosion resistant coating
 Adhesive Tape	108' roll	AL13 double-sided acrylic adhesive tape

## Product Legend: Install Kit

Install Kit Components	Size / piece	Material
 <p>80T Non-ferrous Saw Blade</p>	10" - each	Carbide tip / high-speed steel
 <p>60T Non-ferrous Saw Blade</p>	6-1/4" - each	Carbide tip / high-speed steel
 <p>Gloves</p>	pair	Rubber / lycra
 <p>SLED: Flat</p>	each	Plastic and rubber
 <p>SLED: Reveal</p>	each	Plastic and rubber
 <p>SLED: Corner</p>	each	Plastic and rubber
 <p>Suction Cup</p>	each	Coated aluminum

02

## Pro Tips

## Pro Tips

### Panel Layout

It is important to commence work with good construction practice and schedule work with other trades to avoid delays. Once installation begins it must not be delayed for any length of time as damage may occur to the system, substrate or both due to exposure to the elements. Before any installation begins, it is imperative to plan the layout of the system. The architectural plans/elevations should be reviewed to determine the appropriate 'grid' for the system. Should no such plans be available, measure areas to develop a pattern that will maximize panel size, aesthetics and minimize fabrication.

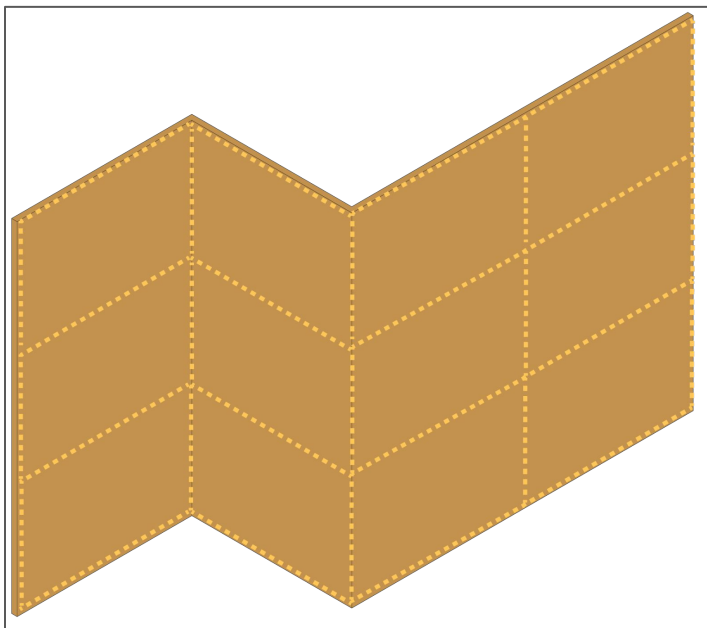

**Note:** Standard panel size is 4 ft x 8 ft (1220 mm x 2440 mm). Do not use these dimensions for determining layout lines. Adequate space must be left between panels for extrusions.

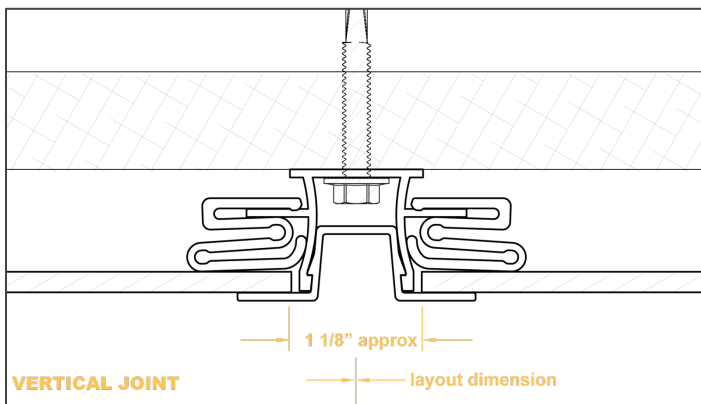

**Note:** The appropriate panel fit should account for approximately a 1/16" gap on all sides to allow for expansion and contraction of the metal.

---

## Pro Tips

### Material Use

Once the layout has been determined, double check that there is an adequate amount of materials present for the application at hand. Since estimation takeoffs and quantities are based on panel layout, any installation varying from the original plan may affect quantities and cause material shortages.

Make sure to check the cut plan to determine if this will result in any further shortages. When calculating material usage, note that vertical extrusions - in most cases - will carry through continuously, while the horizontals tuck and terminate under the tabs of the verticals.

See the Product Legend in the previous section for reference.

---

## Pro Tips

### System Clip, Compressible

The System Clip Compressible provides a perfect fit between the framing components and the panel without the need for extra fasteners, adhesives, or caulking. Familiarize yourself with installing the System Clip Compressible correctly in order to achieve this perfect fit.

#### CORRECT

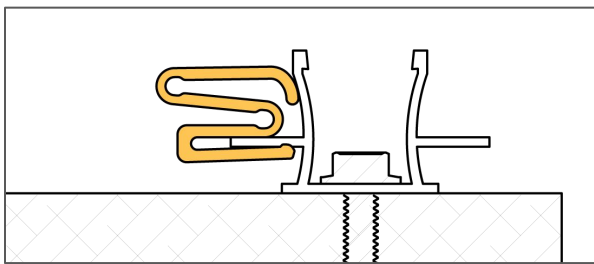

Install the system clip correctly by ensuring the Backplate is inserted into the engaging slot as shown.

The System Clip Compressible should glide in easily and snap into the Backplate when fully inserted.

---

#### INCORRECT

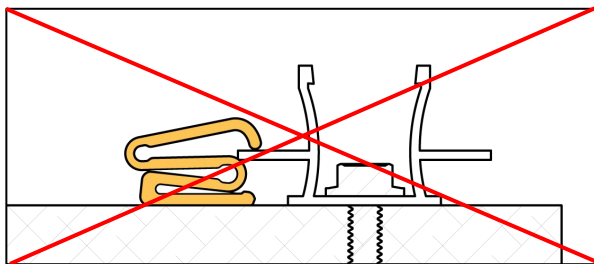

Note that the System Clip Compressible presses up against the panels, hence the majority of its body needs to rest towards the panel.

This incorrect installation will not provide the correct fit between the framing and the ACM panels.

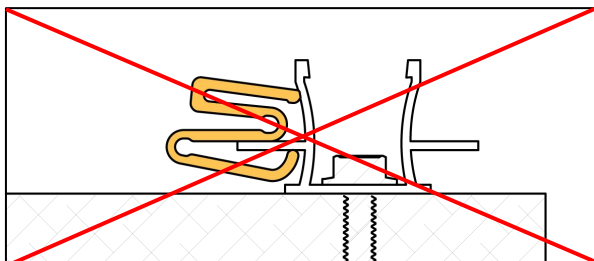

This incorrect, upside-down installation will also not provide the correct fit between the framing and the ACM panels.

## Pro Tips

### Supported Substrates

#### Wood Frame with OSB/Plywood Sheathing

For installation on wood substrates, plywood, and OSB, AL13® Wood Fasteners must be used. For sheathed wood frame, AL13® installs directly on building wrap. The mechanical fasteners anchor into building sheathing and studs where available.

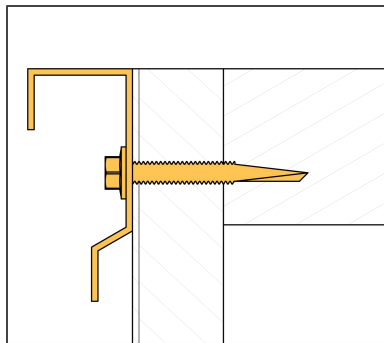
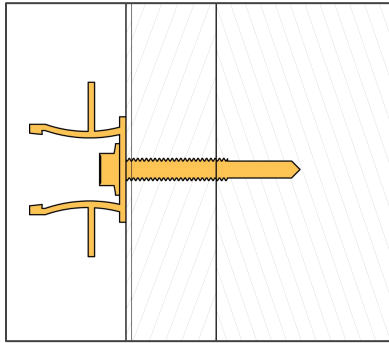

#### Girt/Furring Bar Installation

For installation on girt or furring bars, use metal fasteners.

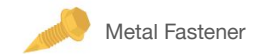
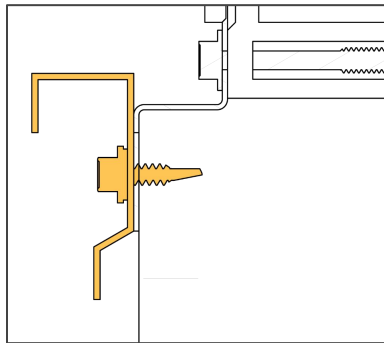
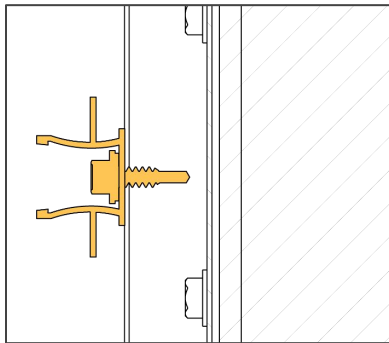

#### Concrete Installation

For installation on concrete, use concrete fasteners/anchors.

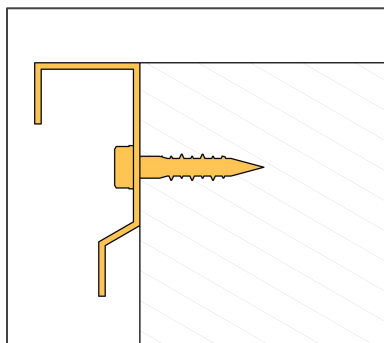
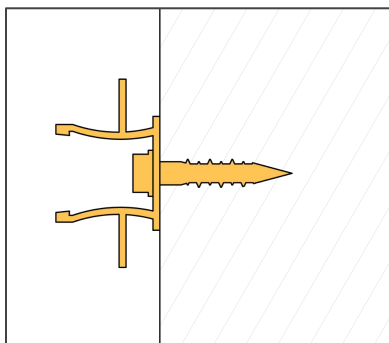

## Pro Tips

### Installing the Top Caps

Panels are fastened by the frame tabs on the top caps around the entire perimeter. No traditional mechanical fasteners are required in the panel itself.

Ensure that the correct **Snap-Lock Engagement Device (SLED)** is used for the appropriate cap. Use a rubber mallet together with the appropriate SLED to install the top caps.

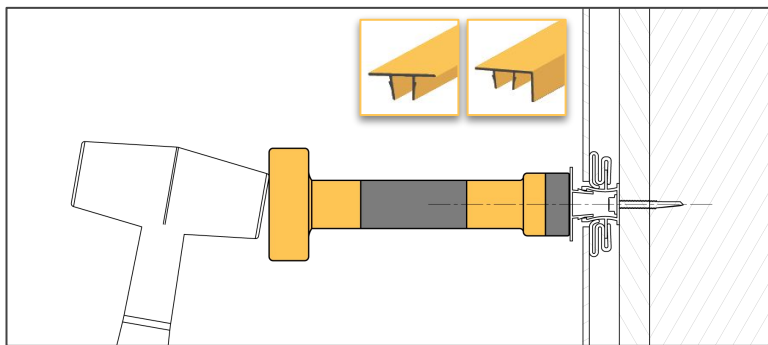

Flat Cap and Flat Cap, Perimeter require the **Flat SLED**

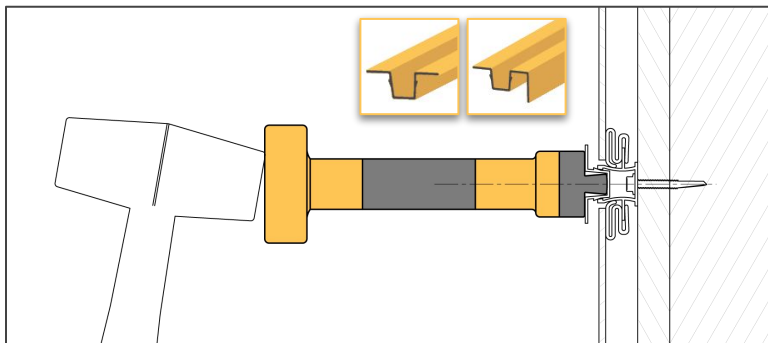

Reveal Cap and Reveal Cap, Perimeter require the **Reveal SLED**

A protrusion at the bottom of the SLED fits inside the reveal of the cap to ensure proper installation.

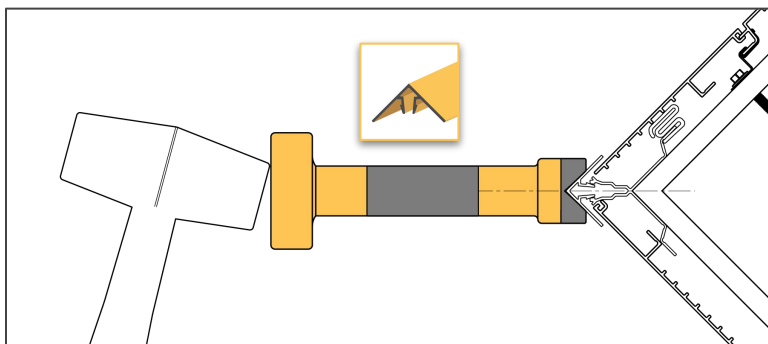

Two-Piece Outside Corner Cap requires the **2OC SLED**

A cutout at the bottom of the SLED captures the geometry of the Outside Corner cap to ensure proper installation.

## Pro Tips

### Installation near Windows, Doors, and other Bump-Outs

When installing around a perimeter terminated with a Back Plate Universal, leave a minimum gap of 1/16" from the edge of the Back Plate to the perimeter border. This allows sufficient space for a top cap to be installed.

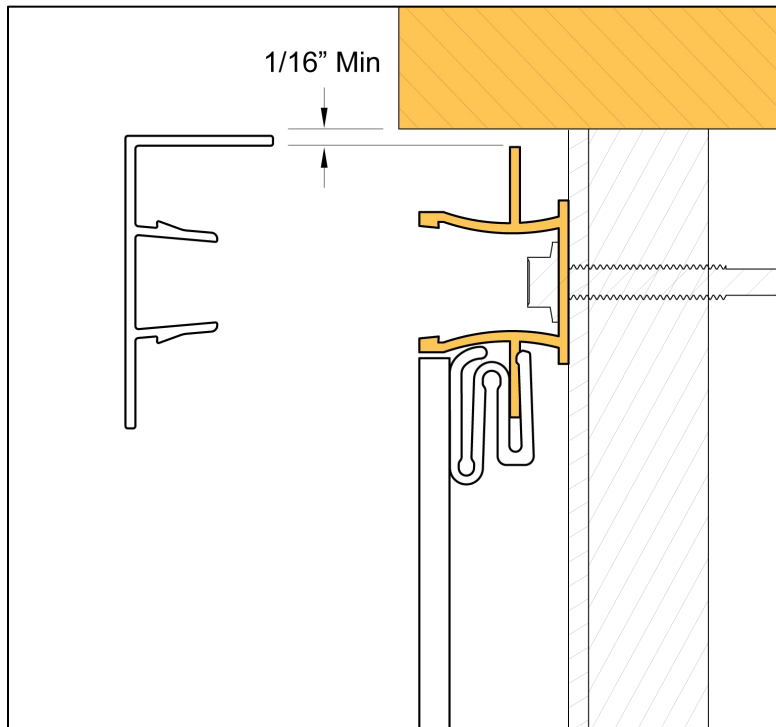

Leave a minimum of 1/16" gap between the edge of a perimeter (e.g., windows, doors, bump-outs) and the Back Plate Universal.

## Pro-Tips

### Fascia Installation with Non-AL13 Soffit

The **Back Plate, Extended** is used for the bottom perimeter of the fascia specifically when a non-AL13 material is used for the soffit. The bottom edge of the **Back Plate, Extended** can be offset from the fascia edge by up to 1.5in. This provides allowance for the fascia to cover the edge of a non-AL13 soffit.

If the soffit is AL13 Plank or Panel System, use 2-Piece Outside Corner

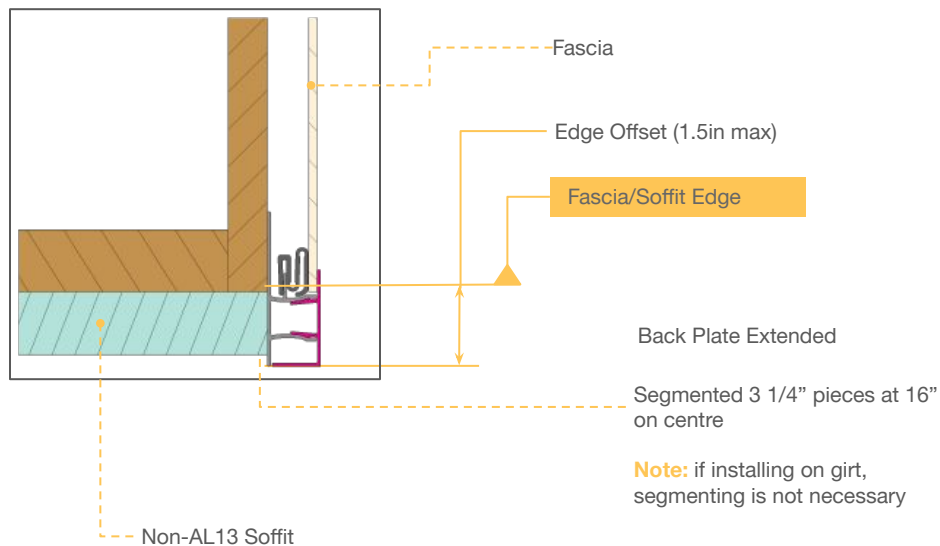

### Bottom of Floor Installation

The **Back Plate, Extended** is used for the lower horizontal edge of the bottom floor where the substrate meets the foundation (typically concrete). The bottom edge of the **Back Plate, Extended** can be offset by up to 1.5in.

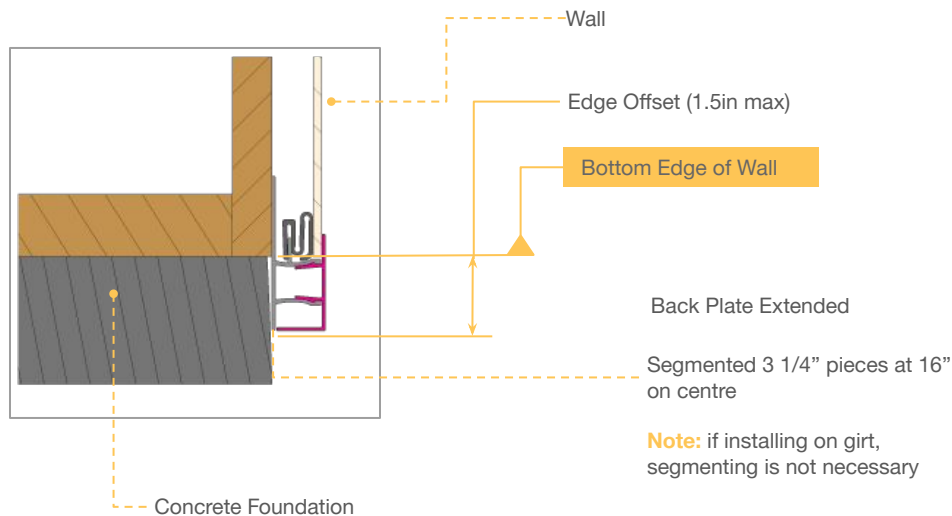

## Pro Tips

### I-Beam Installation

I-Beam installation (optional). I-beams may be used in conjunction with the panels to provide additional panel rigidity.

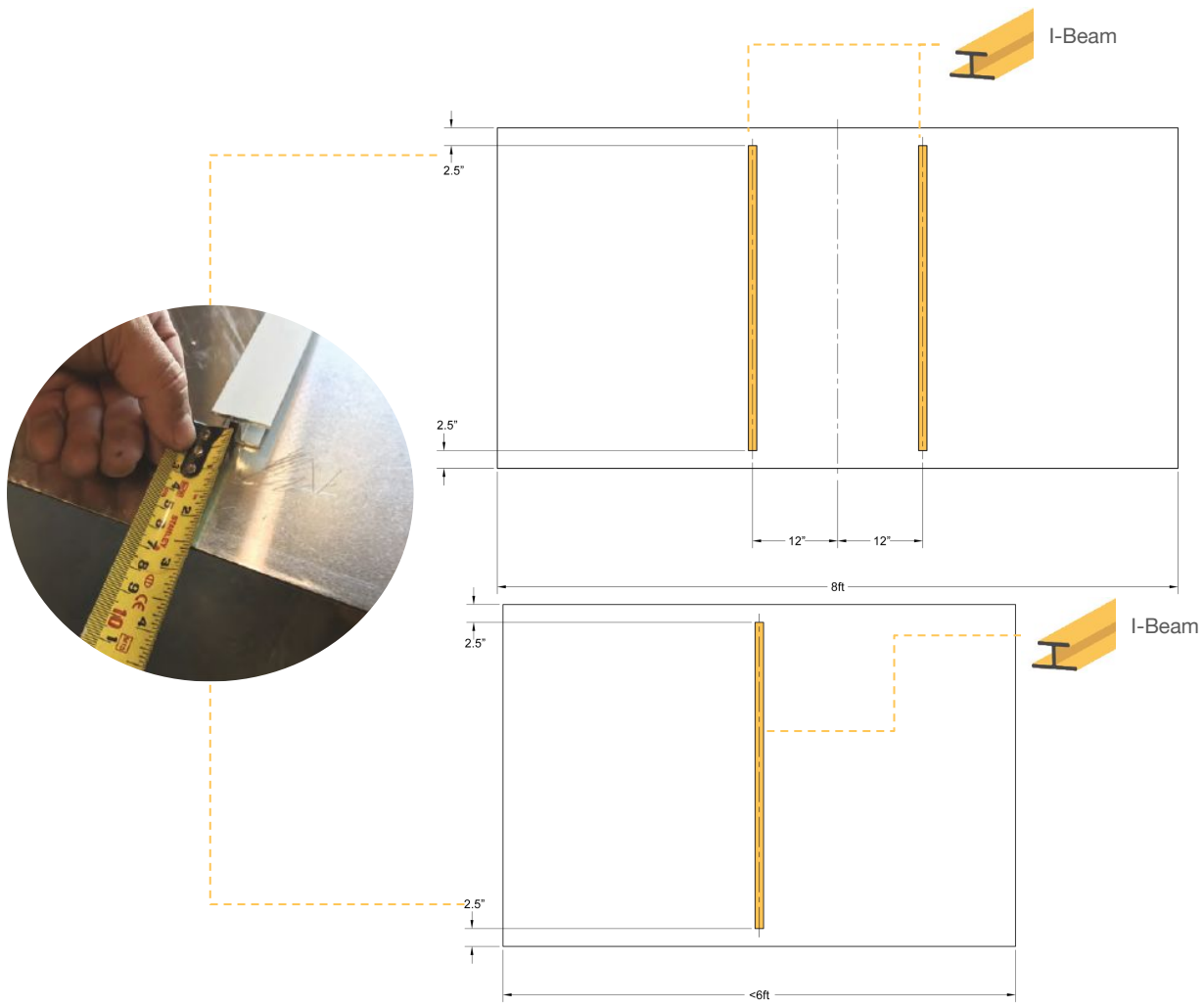

**Step 1** - Cut I-beams to fit.

Appropriate sizing should be offset from either edge of the panel 2 1/2". Full 4 ft x 8 ft panels will require 2 I-beams set back 12" from the centre. Panels 6' or below only require 1 I-beam, running in the narrow direction, at the center of the panel.

**Step 2** - Ensure both of the surfaces are free of dirt, debris or contaminants to ensure full adhesion. For best performance it is suggested to clean both surfaces using Isopropyl Alcohol, which is free of solvents and will not damage any finished surfaces.

**Step 3** - Apply double-sided adhesive the full length of the narrow leg of the I-beam. Remove the protective backing and carefully attach to the cleaned back side of the panel. Once set in position, apply pressure along the length of the I-beam to ensure even full contact with the back side of the panel.

## Pro Tip

### Take-Off Extrusion Legend

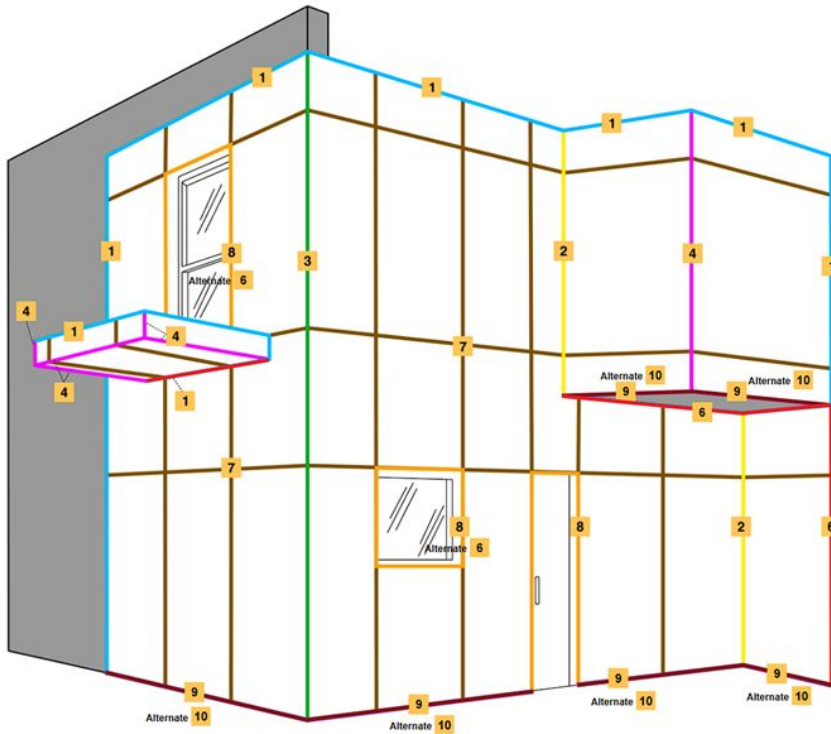





Project take-offs by AL13 follow the colour and icon convention shown here to identify the extrusions installed at a specific location.







The guides in the following sections illustrate the recommended order of installation of the extrusions to facilitate the installation of the panel sections.

**Caution:** Ensure panels are installed prior to engaging the appropriate top cap.

#### One-Piece Extrusions

- 0**  2" VENTED STRIP PLANK Soffits  
Deep Indigo
- 1**  END FRAME  
Installed wall side // top wall\*  
Cyan
- 2**  INSIDE CORNER  
90° inside corners\*  
Bright Yellow
- 3**  OUTSIDE CORNER  
90° outside corners\*  
Green

#### Two-Piece Extrusion Assembly

- 4**  TWO-PIECE OUTSIDE CORNER  
90° outside corners\*  
Magenta
- 5**  FLAT CAP with  
BACK PLATE, UNIVERSAL  
Bottom of Walls // Between Planks  
Purple
- 6**  FLAT CAP, PERIMETER with  
BACK PLATE, UNIVERSAL  
Wall sides / balcony / bump-out  
Red
- 7**  REVEAL CAP with  
BACK PLATE, UNIVERSAL  
Between Panels  
Brown
- 8**  REVEAL CAP, PERIMETER with  
BACK PLATE, UNIVERSAL  
Around windows / doors / openings  
Orange
- 9**  FLAT CAP, PERIMETER with  
BACK PLATE, EXTENDED  
Bottom of Fascia / bottom of ground floor  
Maroon
- 10**  REVEAL CAP, PERIMETER with  
BACK PLATE, EXTENDED  
Bottom of Fascia / bottom of ground floor  
Peach

03

## Standard Wall Installation

## Panel Install

Example Wall: Cutaway View

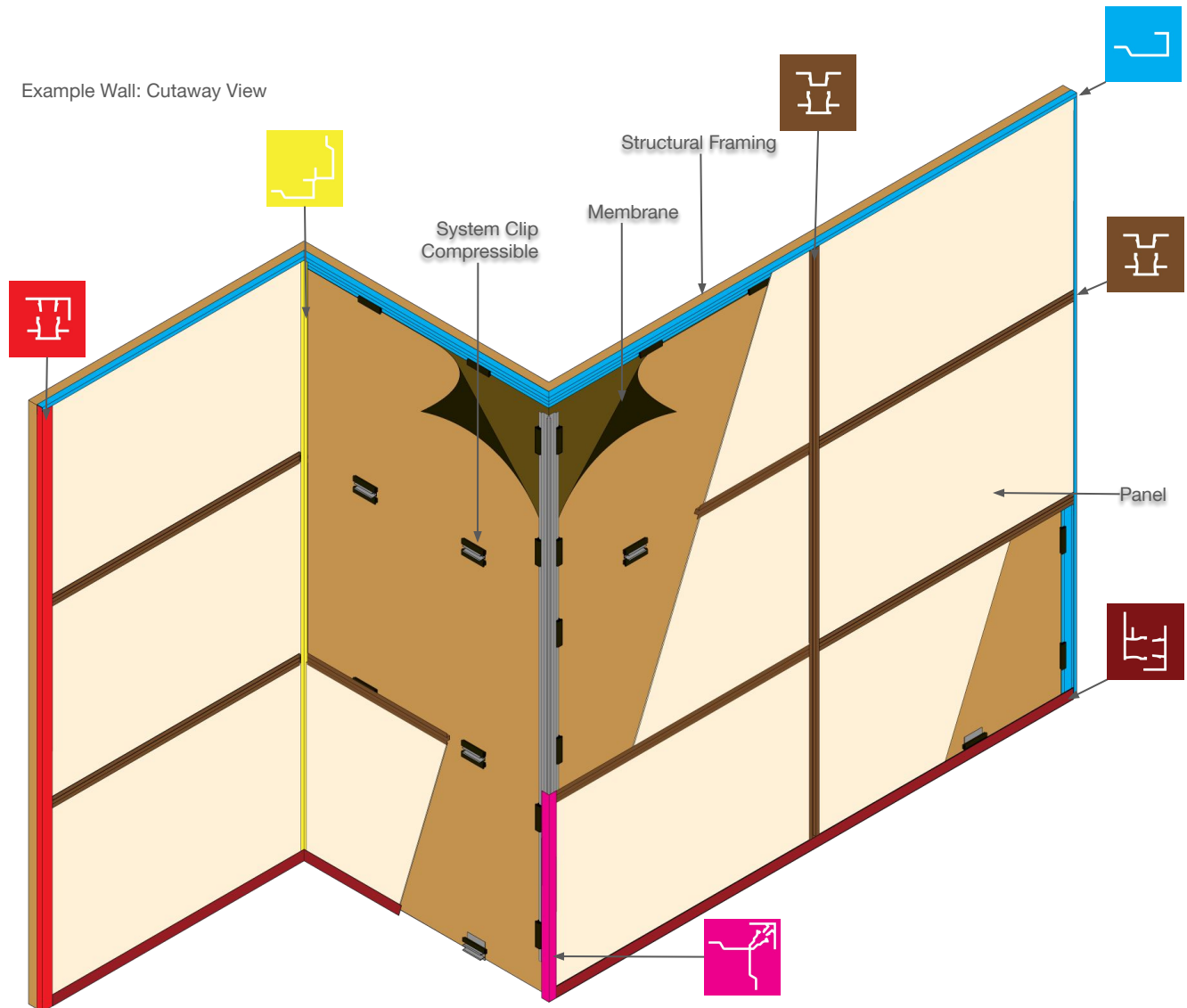

The first part of the installation guide outlines a basic install on a wall with a return as illustrated above in its completed form.

The next steps outline details such as inside corners, outside corners, windows, doors, overhangs, and build-outs (Please be sure to have read the General Install section first).

**IMPORTANT:** The building envelope, which includes a weather barrier and all applicable flashings, must be completed to local building code before any AL13® component is to be laid out or installed.

The extrusion colours are based on the **Take-Off Extrusion Legend**; see Section 02 for reference.



**Caution:** The backplates and various caps use an interference fit and require an impact to engage the two components. Ensure that the substrate is solid enough to sustain this impact.

---

## Panel Install

Example Wall

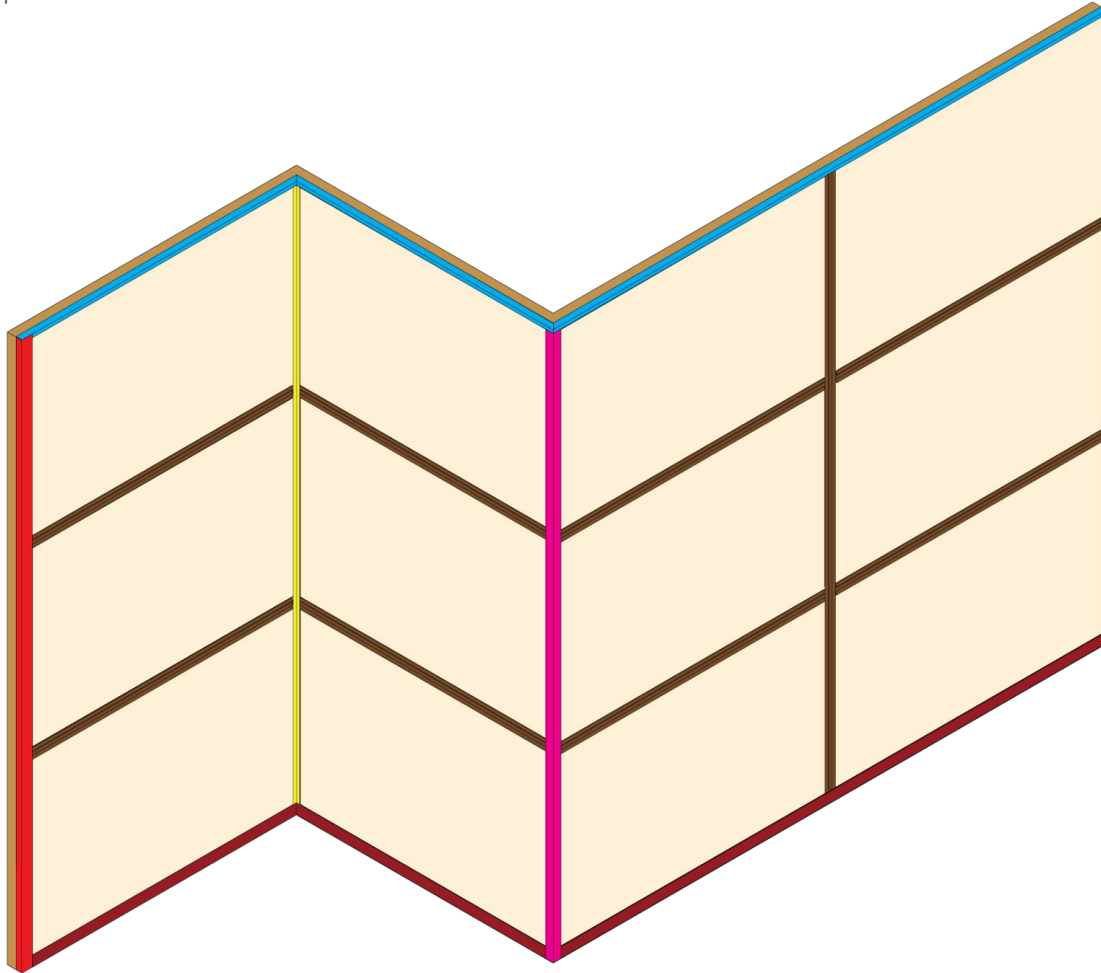

---

The first part of the installation guide outlines a basic install on a wall with a return as illustrated above in its completed form.

The next steps outline details such as inside corners, outside corners, windows, doors, overhangs, and build-outs (Please be sure to have read the General Install section first).

**IMPORTANT:** The building envelope, which includes a weather barrier and all applicable flashings, must be completed to local building code before any AL13® component is to be laid out or installed.

The extrusion colours are based on the **Take-Off Extrusion Legend**; see Section 02 for reference.

## Panel Install

Lay out the grid.

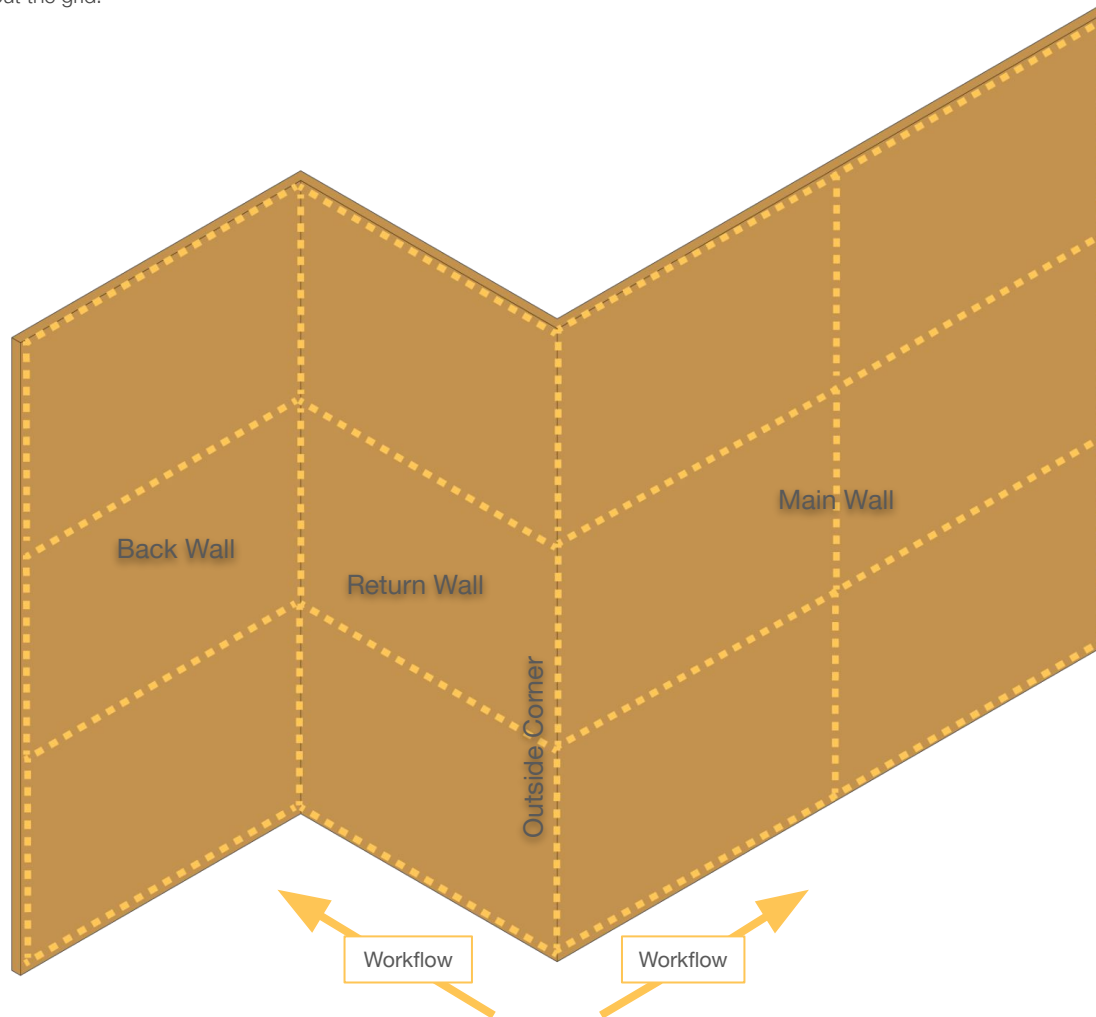

Refer to your building plans to determine the layout.

In this example, the main wall is two panels across and three panels high; the return wall and back wall are one panel across and three panels high.

Using the chosen layout, determine the best suited datum - or starting point - shown here as the lower left corner/outside corner.

Lay out the panel grid using chalk lines (or similar) from the datum point, ensuring that all lines are plumb or level. These lines are to indicate the locations of the extruded frame components that will secure and frame the ACM panel.

Follow the directions of the arrows when considering your workflow.

Also ensure that **two** one-piece extrusions are **NOT** parallel to each other to frame one panel. It is important to have a two-piece extrusion assembly on the opposing side to facilitate panel installation.

## Panel Install

Return and back wall installation.

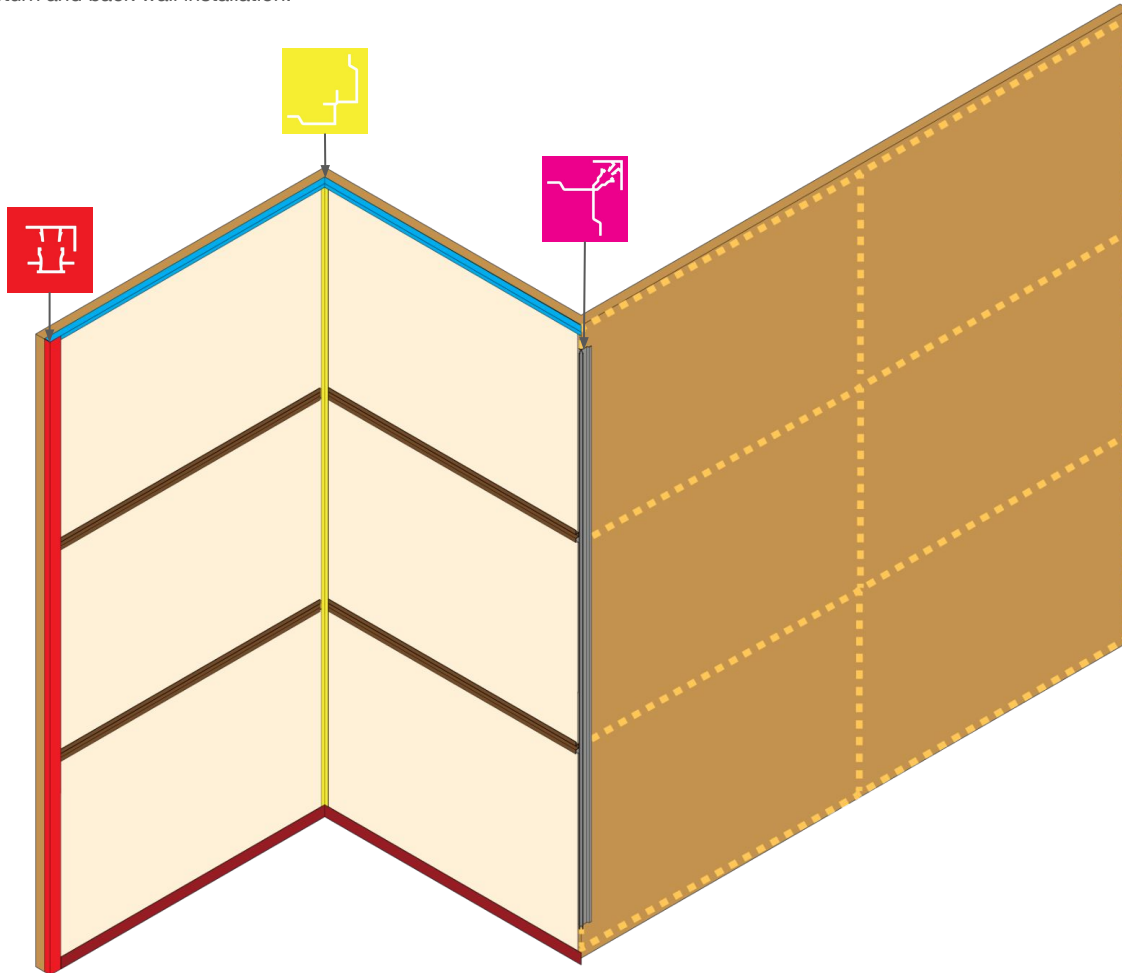

In this example, the return wall is only one panel wide. The Inside corner must be paired with a two-piece extrusion along the parallel edge. A two-piece outside corner is used in this case.

Only the Two-Piece Outside Corner back plate is installed prior to finishing the main wall. The corresponding top cap is installed towards the end of installation.

The back wall shares the inside corner with a return wall. Since this is a one-piece extrusion, the wall is terminated with a two-piece extrusion, which is a Flat Cap, Perimeter paired with a Back Plate, Universal.

## Panel Install

Fasten End Frame extrusions.

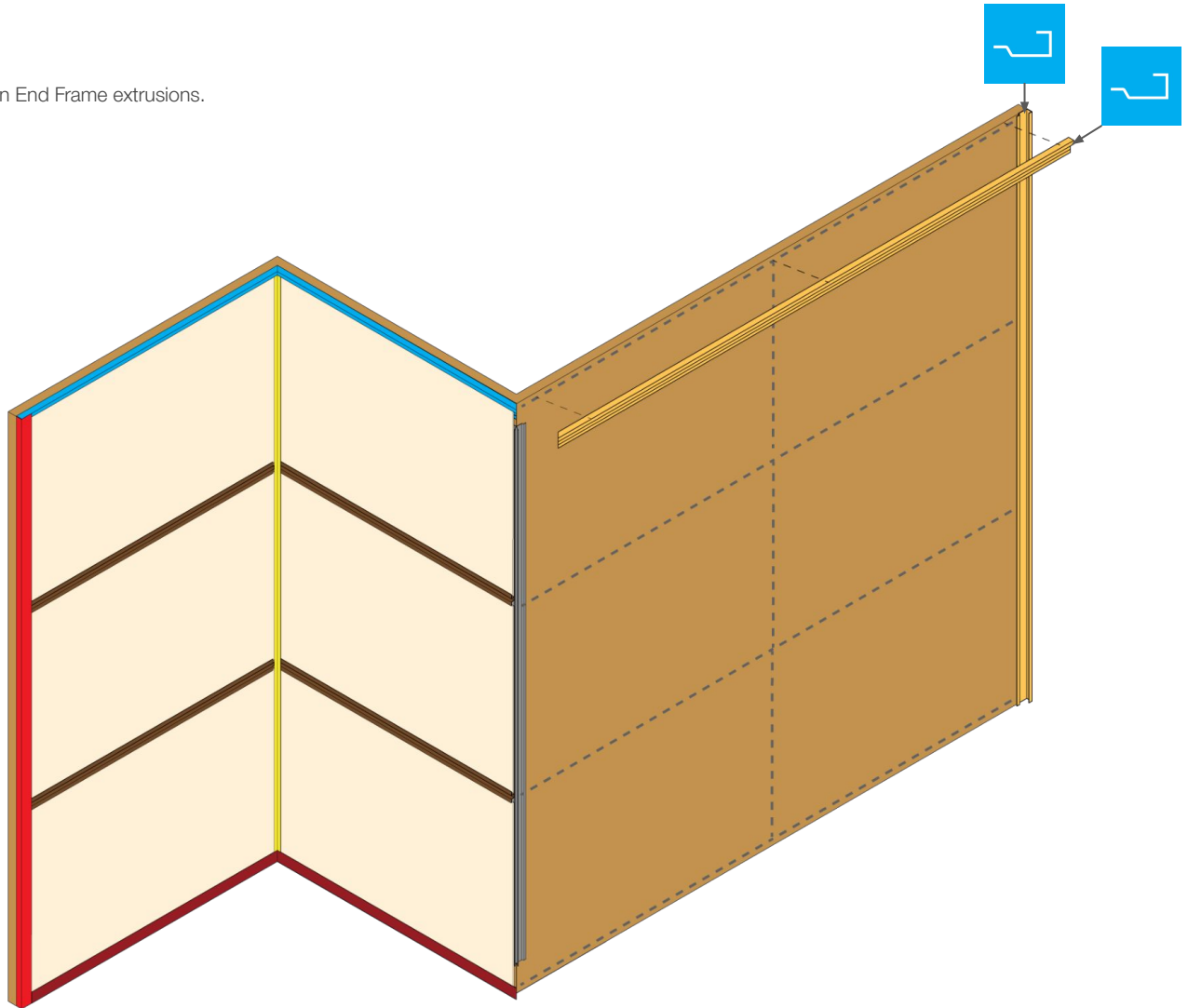

Measure and cut the End Frames according to the marked grid lines. If the top of the vertical End Frame is to meet another horizontal End Frame at 90 degrees, a 45-degree mitre cut is to be made on both parts to complete the angle. This will eliminate the need to notch extrusions. If the wall is to be finished with a half back plate and perimeter cap, the 45-degree mitre is not necessary, as the horizontal cap will tuck behind the vertical end frames.

The preferred method to install the extrusion is to fasten the top part first (upper 3"), then the bottom (lower 3"), followed by all fasteners in between. Typical fastener spacing on all extrusions with the Panel system is to be **no greater than 24"** with a **minimum of 2 fasteners per extrusion**. Fastener spacing may be increased, to add additional pull out capacity. Consult the fastener specifications guide to determine fastener type and spacing.

If one length of the End Frame extrusion is not long enough to span the distance required, it is necessary to use a second piece and butt the two together. Take care in aligning joints so that they are flush, shim as needed.

## Panel Install

Fasten/install bottom of wall (bottom of floor) extrusions. Use the **Back Plate, Extended** for the lower fascia edge shared with the soffit. Measure and cut the back plates, allowing for a 2in gap between the horizontal upper and lower extrusions.

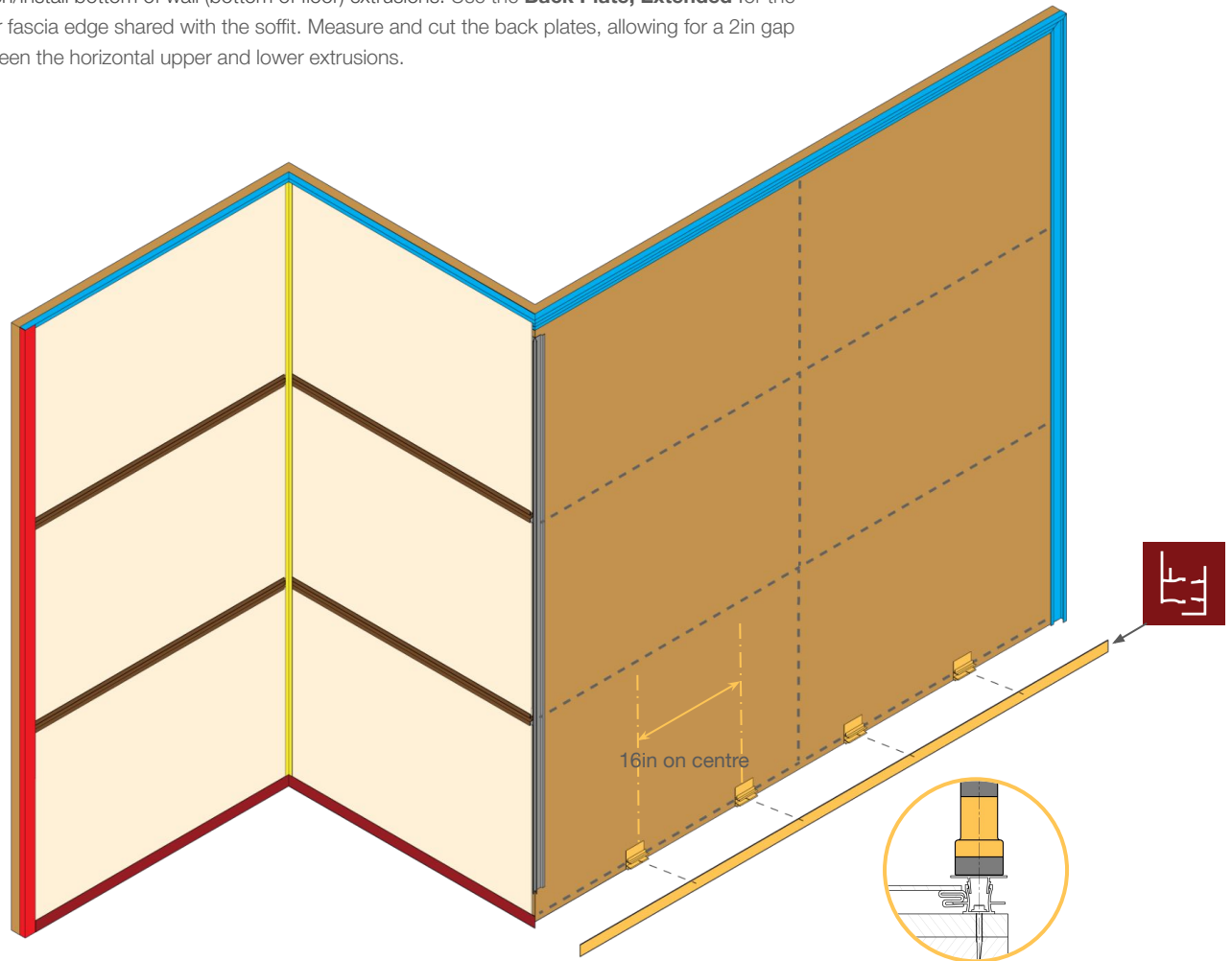

The bottom row comprises segmented back plate sections, cut to a length of 3-1/4in and installed every 16in. This ensures that, at any given horizontal cutaway, only 20 % of the material is attached to the wall to an 80 % open cavity. This provides necessary capillary break and fulfills the rainscreen requirements.

**Note:** If installing on girt, segmenting the back plates is not necessary.

Note the **Back Plate, Extended** is used for the bottom perimeter of the bottom floor only.

If the pattern continues to a second floor, the bottom of the wall would use a **Back Plate, Universal**.

Measure and cut the bottom horizontal top cap. A proper fit will ensure that either end may be tucked into the vertical end frames, leaving a minimum 1/16in gap to allow for proper contraction and expansion of the extrusion.

Engage the top cap into the segmented back plates using an AL13® SLED with a rubber mallet. It is imperative to only make contact where back plates are present so as not to damage or warp the top cap.

## Panel Install

Fasten vertical and horizontal back plates.

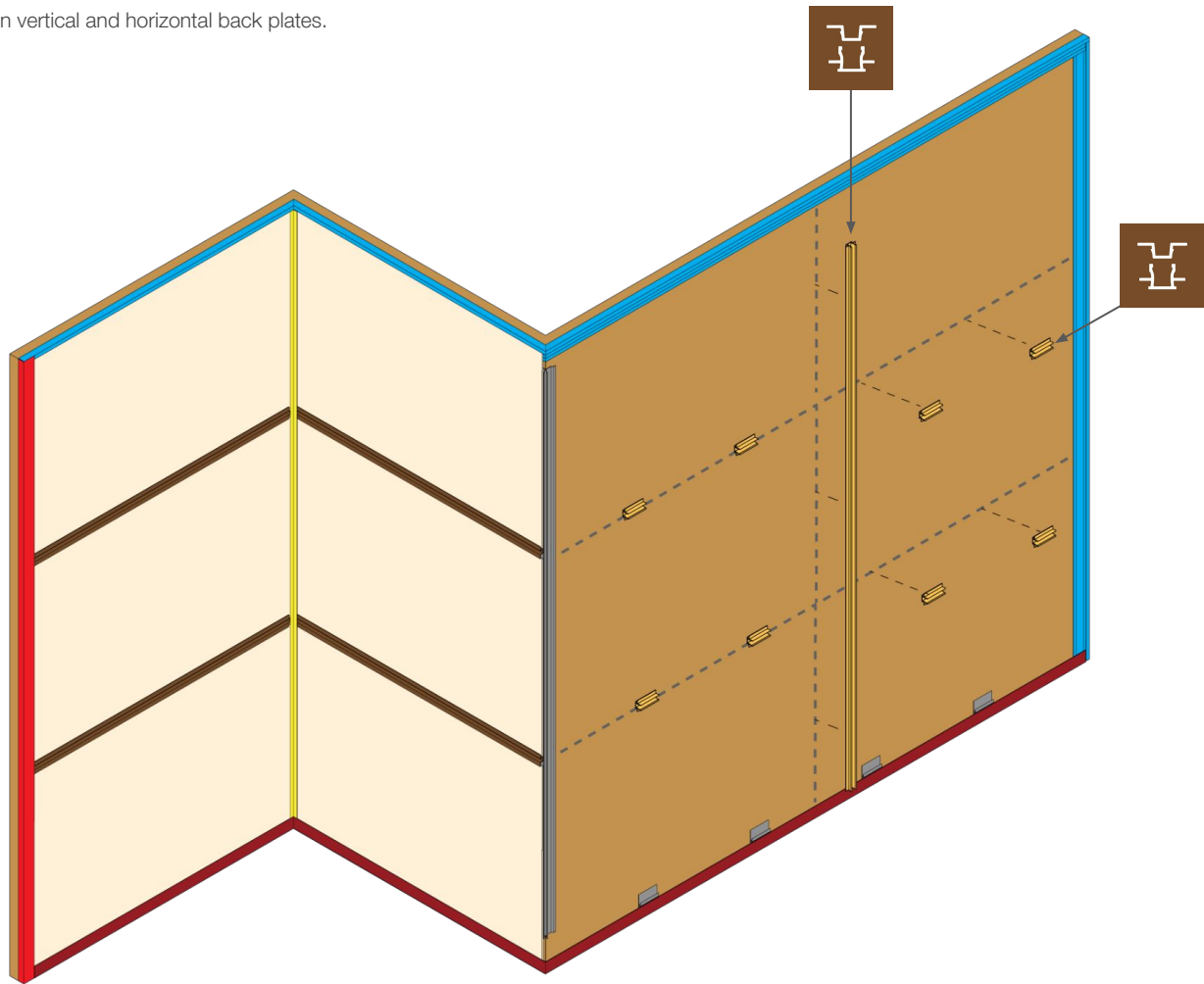

Measure and cut the vertical back plate. Allow for approximately 2" gap from horizontal upper and lower extrusions to allow for proper top cap installation. Begin by fastening the top of the extrusion first (upper 3"), followed by the bottom (lower 3"), then the intermediate fasteners.

**Note:** allow for approximately a 2in gap from the upper and lower horizontal extrusions

Measure and cut horizontal back plates in 3 1/4" segments and install them every 16" as per the layout. If you are fastening to a minimum of 1/2" ply or OSB sheathing, it is not necessary to fasten segments to a stud. It is recommended to pre-drill the holes in the segmented back plate pieces. This will prevent the small pieces from spinning while fastening - which aides in eliminating the possibility of a cut hazzard.

It is important to install the segments ensuring they are completely plumb and straight. A Level or straight edge may be used to assist with alignment.



**Caution:** In some installations, more than a full length of a top cap may be required. In this case, ensure that the seam is supported adequately by a back plate.

## Panel Install

Attach system clips.

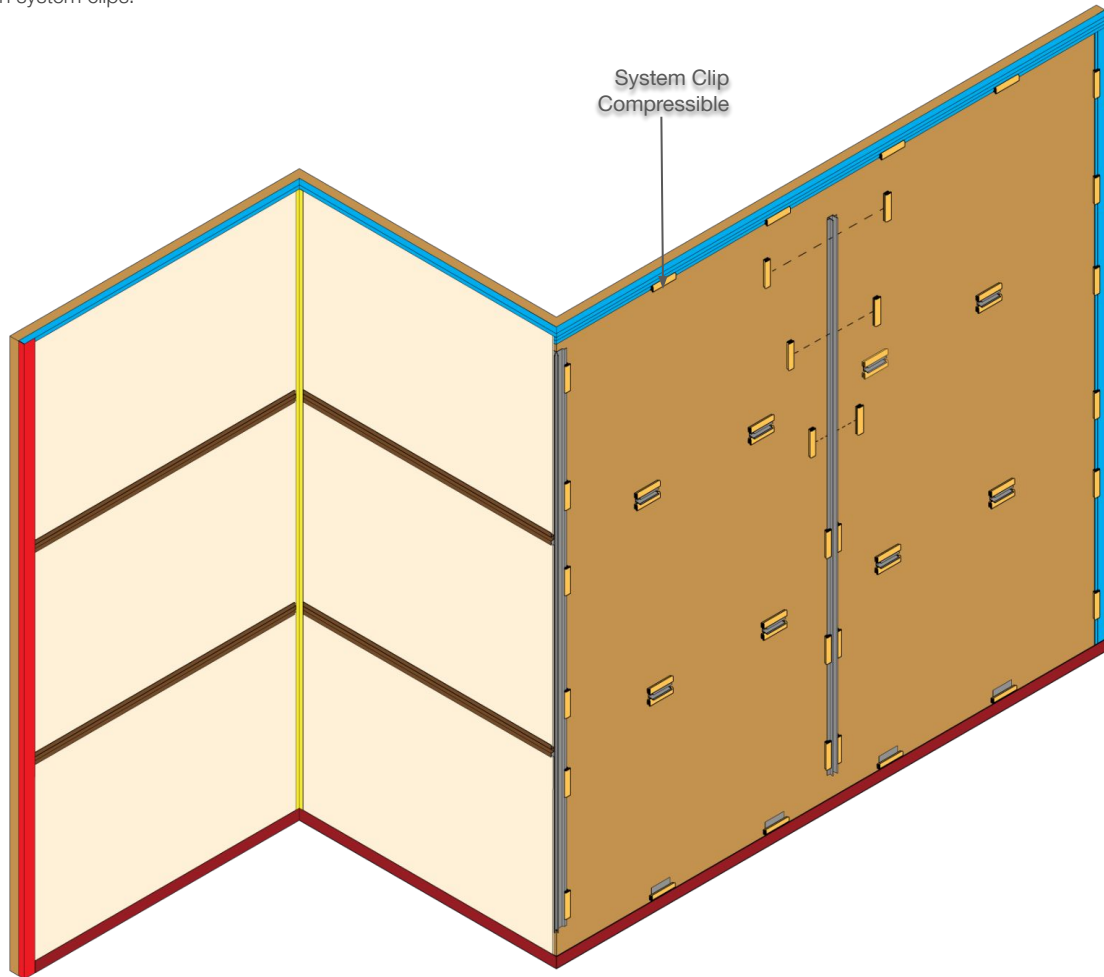

Once all extrusions have been installed it is time to attach system clips to all the extruded frame components.

System clips act as spacers and are installed with the thin tab pointing towards the wall and the thicker portion facing away from the wall. System clips keep the panels tight to the frame without the need for adjustment.

System clips are to be **attached at a minimum every 16"**, or 1 system clip per tab on the smaller segmented horizontal pieces. Position system clips 3in-4in away from corners and intersections.

Refer to Pro Tips section to ensure correct installation orientation of the System Clip, Compressible.

System clips are intended to be a firm and secure friction fit. Repeated attempts pulling the clip off and snapping it back on may weaken the integrity of a clip. Once a clip has been snapped in place, it should not be repeatedly taken off and snapped back on. If any clip is found to have been weakened through repetitive use, it should be discarded and a new one used in its place to ensure a secure fit.

## Panel Install

Measure panel size for fit.

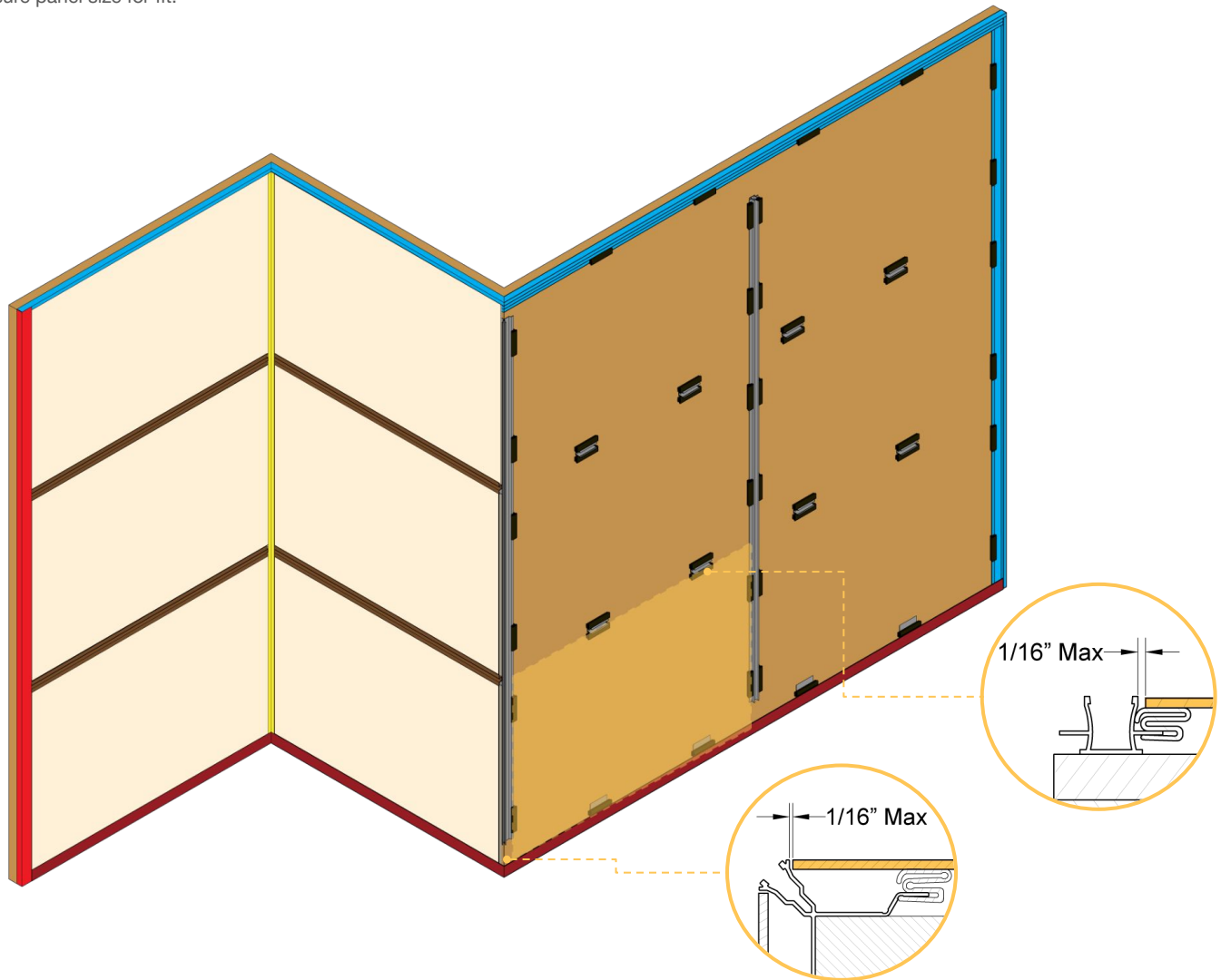

Once a panel is ready to be fit, it may be taken off the stack. Lift the panel up off the stack, then away; do not drag the panels.

Although the panels have a protective film applied from the factory, reckless panel handling may cause damage to the panel through the wrap. It is recommended that at least two persons carry one sheet.

A panel may need to be cut down if a smaller size from the standard 4ft x 8ft (1220 x 2440 mm) is required. This may be done on a standard circular saw, panel saw or table saw - so long as an AL13® blade is used.

Use a guide to ensure cuts are straight and clean. The appropriate panel fit should account for approximately a 1/16" gap on all sides to allow for expansion and contraction of the metal.

Gloves should be worn to keep the panel clean and to protect hands from sharp edges.

## Panel Install

Install the panel closest to the datum.

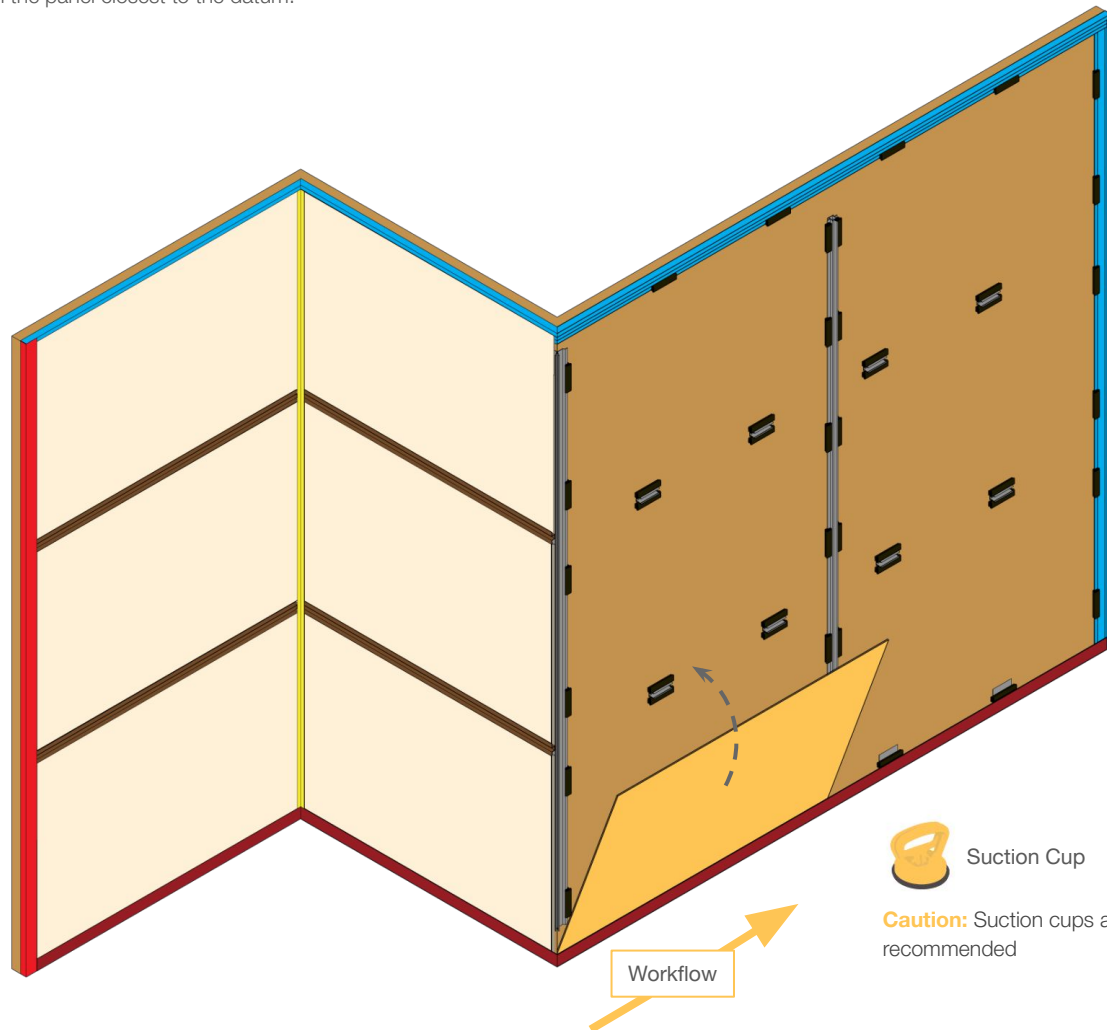

Suction Cup

**Caution:** Suction cups are recommended

The protective film should be peeled back approximately 1" (25 mm) from the edges, but should remain on the panel otherwise.

Suction cups are recommended for installing panels as they allow for much greater grip and free your hands from a potential pinch hazard.

Position the panel on its long edge, as shown, lift it up and place in position. Ensure the bottom edge is between the tab of the bottom cap and the system clips.

Once the bottom of the panel is seated, rotate the panel into position to double check the fit. The edges should be 1/16in away from the back plate.

## Panel Install

Install reveal cap and lock into place with AL13® SLED tool.

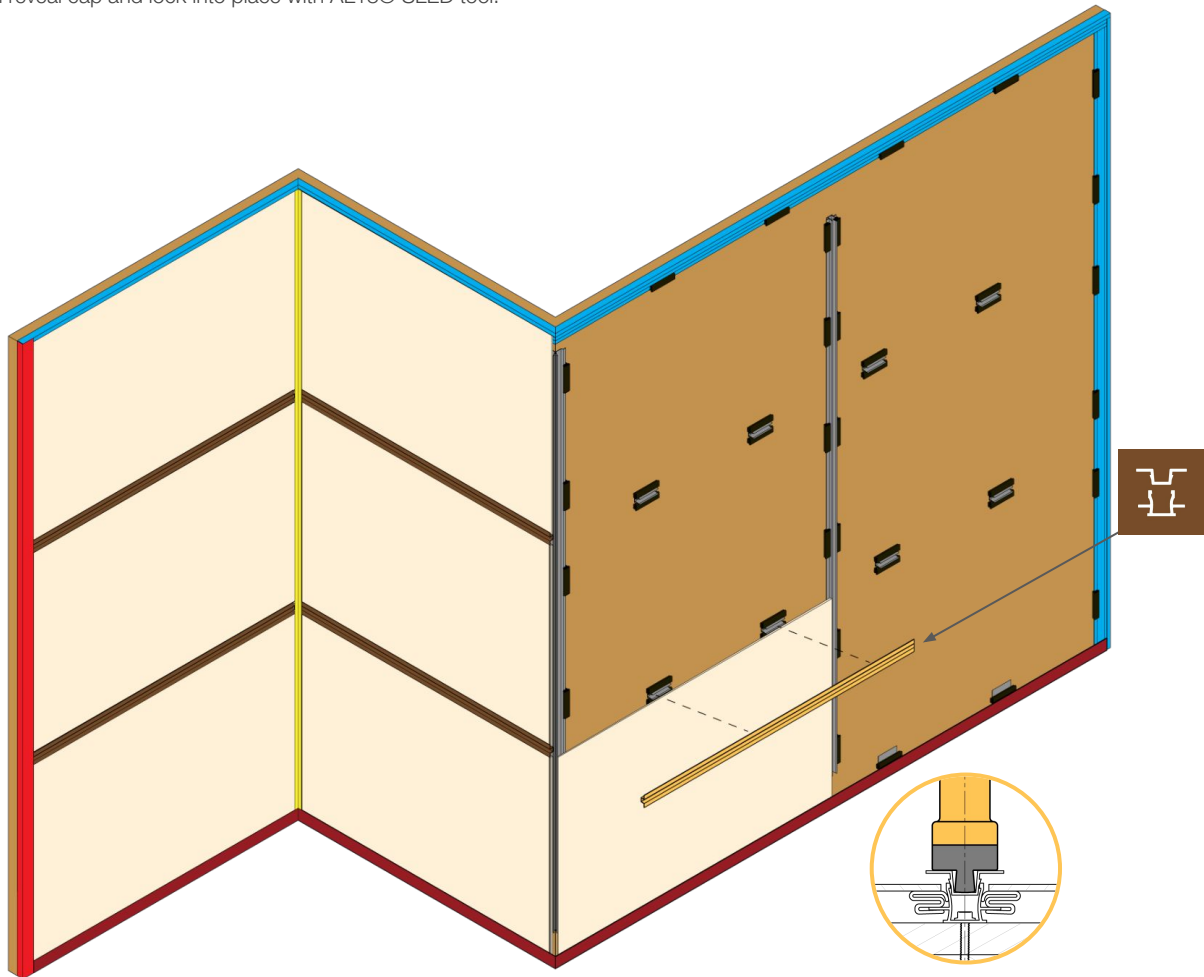

After the panel has been shifted into the correct position you must securely fasten it in place with a top cap. The top cap is the second part of the two-piece extrusion assembly which is snapped into place with a rubber mallet and the AL13® SLED.

Once the top cap is cut to the appropriate length, it may be engaged with a rubber mallet and the AL13® SLED. Be cautious to only impact the top cap where a back plate is present to prevent any deformation of the frame components.

The top cap must come to rest on the vertical back plates. Therefore, they may be cut and positioned to match the panel.

## Panel Install

Repeat previous two steps for the next panel along the workflow.

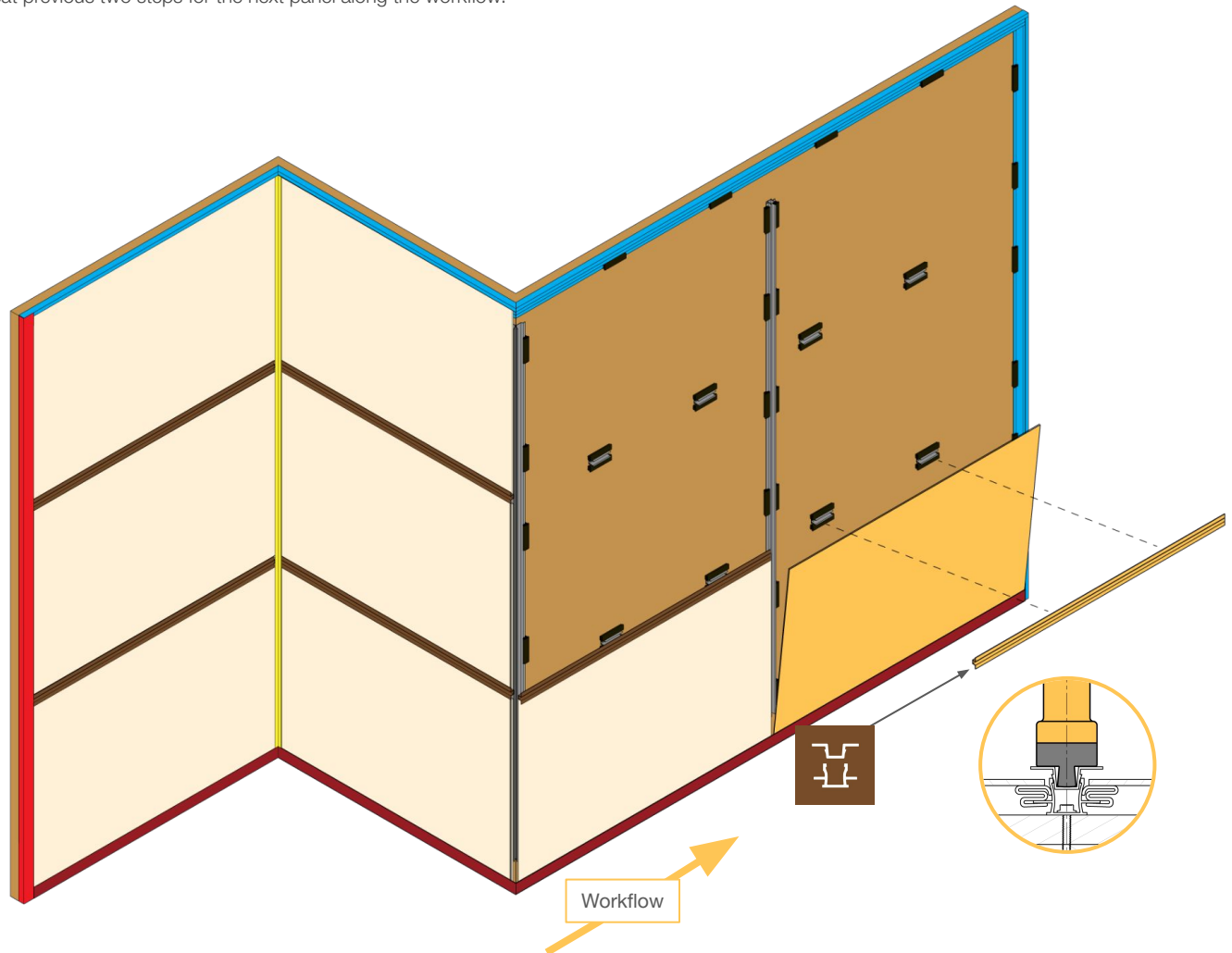

Continue workflow to the right and repeat previous steps for remaining panels on the first row of the wall.

Where a horizontal top cap intersects a vertical End Frame, it should slide under the tab of the End Frame

The horizontal top cap should sit halfway under the tabs of the vertical End Frame components, and rest on the vertical back plate, in the same manner as the panel. Therefore, the horizontal top cap may be cut and positioned to match the panel.

## Panel Install

Install top two panels. Lock top panels into place with top cap.

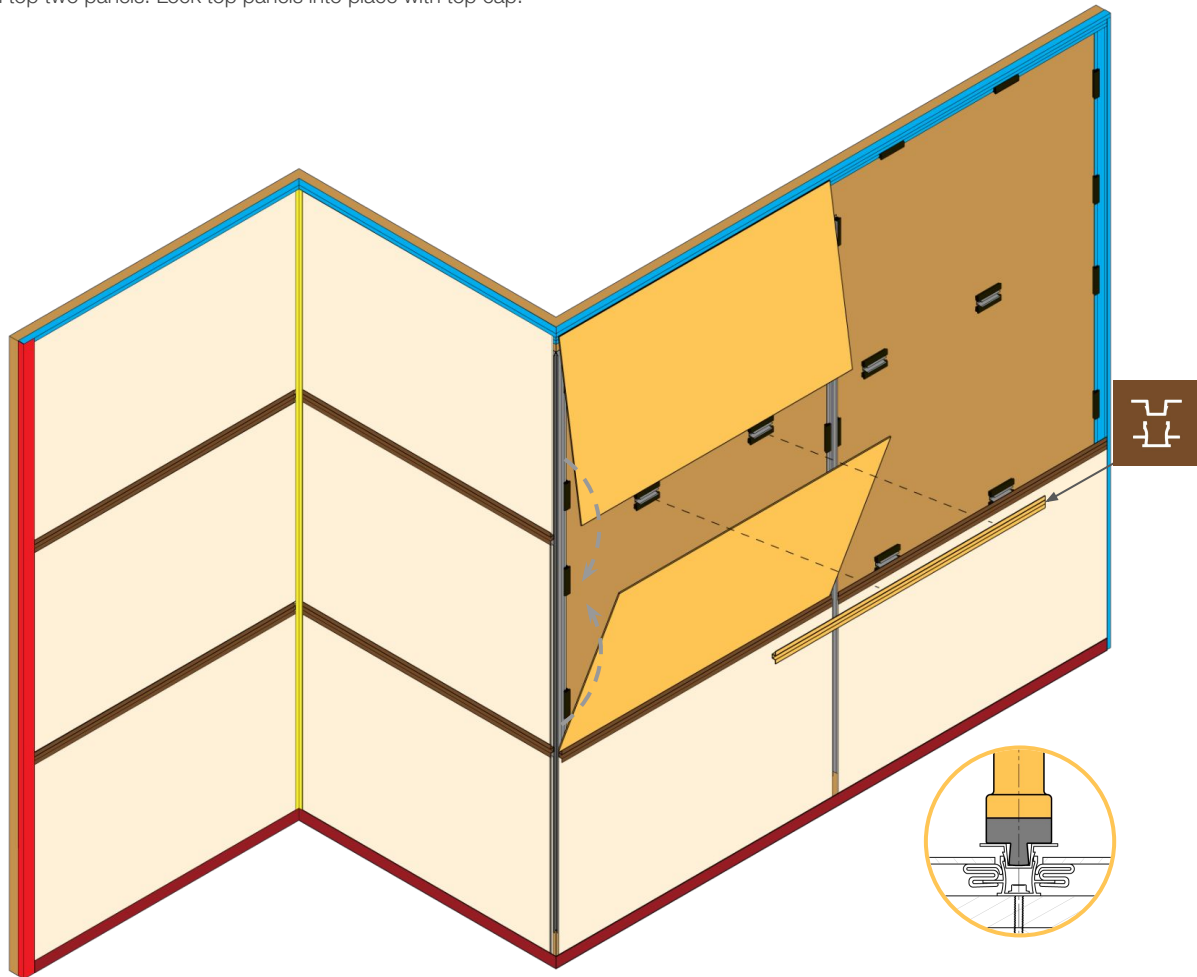

The top two panels in a column must be installed simultaneously. Since the top of the wall terminates under the horizontal End Frame, it would be impossible to place the upper panel if the below top cap was already secured.

**Step 1** - Install lower panel and hold in place while second panel is fitted.

**Step 2** - Slide upper panel upwards under the tab of the horizontal End Frame.

**Step 3** - Slide the panel underneath the vertical End Frame.

After the ACM Panels have been shifted into the correct position, the horizontal top cap will secure the panels in place. Once the top cap is cut to the appropriate length, it should be placed, one end first, into place, with each end under the tabs of the horizontal End Frames.

---

## Panel Install

Repeat for the other side as per the workflow and lock into place.

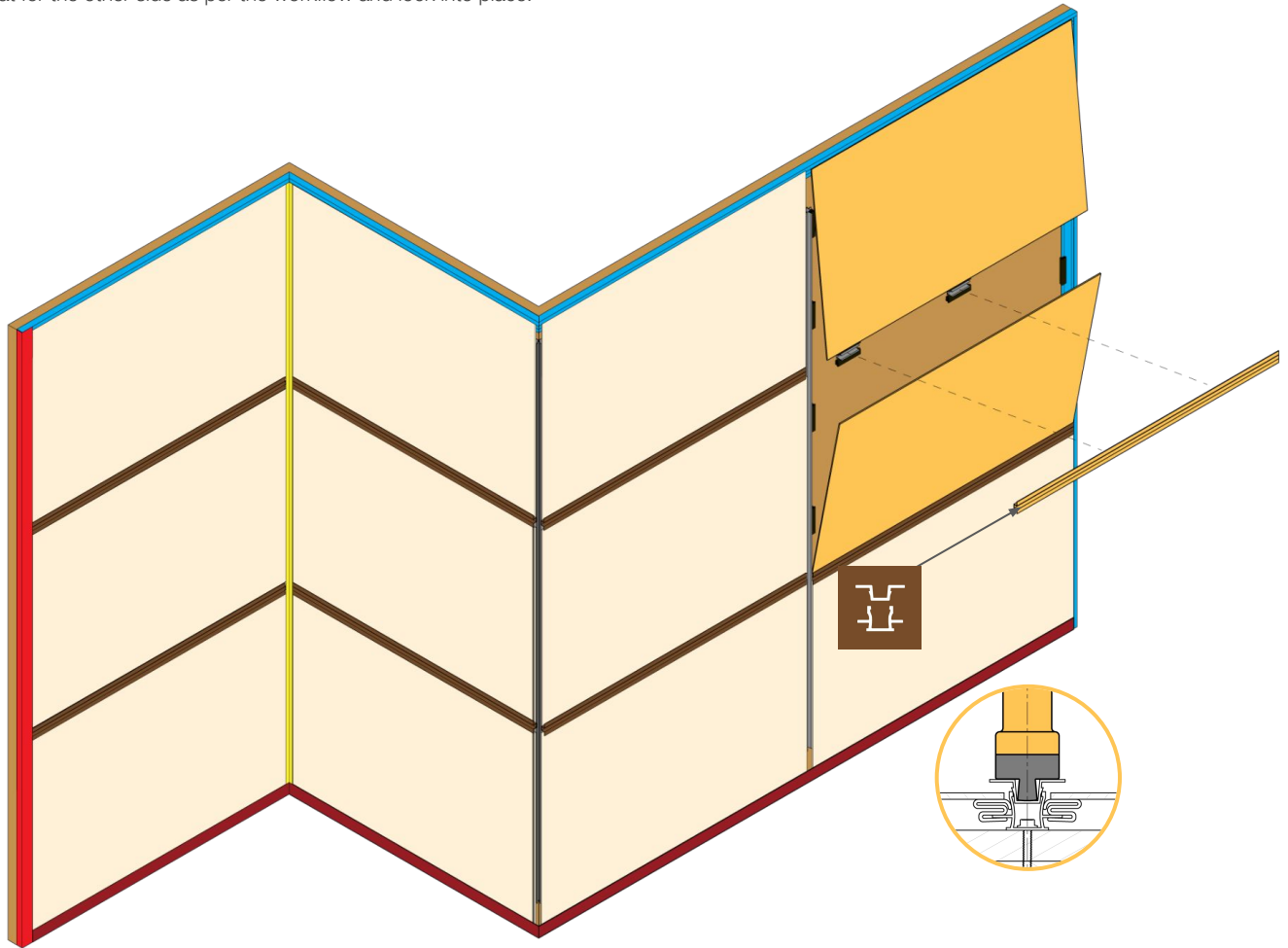

---

Continue workflow to the right and repeat previous steps for remaining panels on the top row.

Once both panels and the top cap are in the correct position, the top cap may be hammered into place with a rubber mallet and AL13® SLED.

## Panel Install

Install vertical top cap and lock into place.

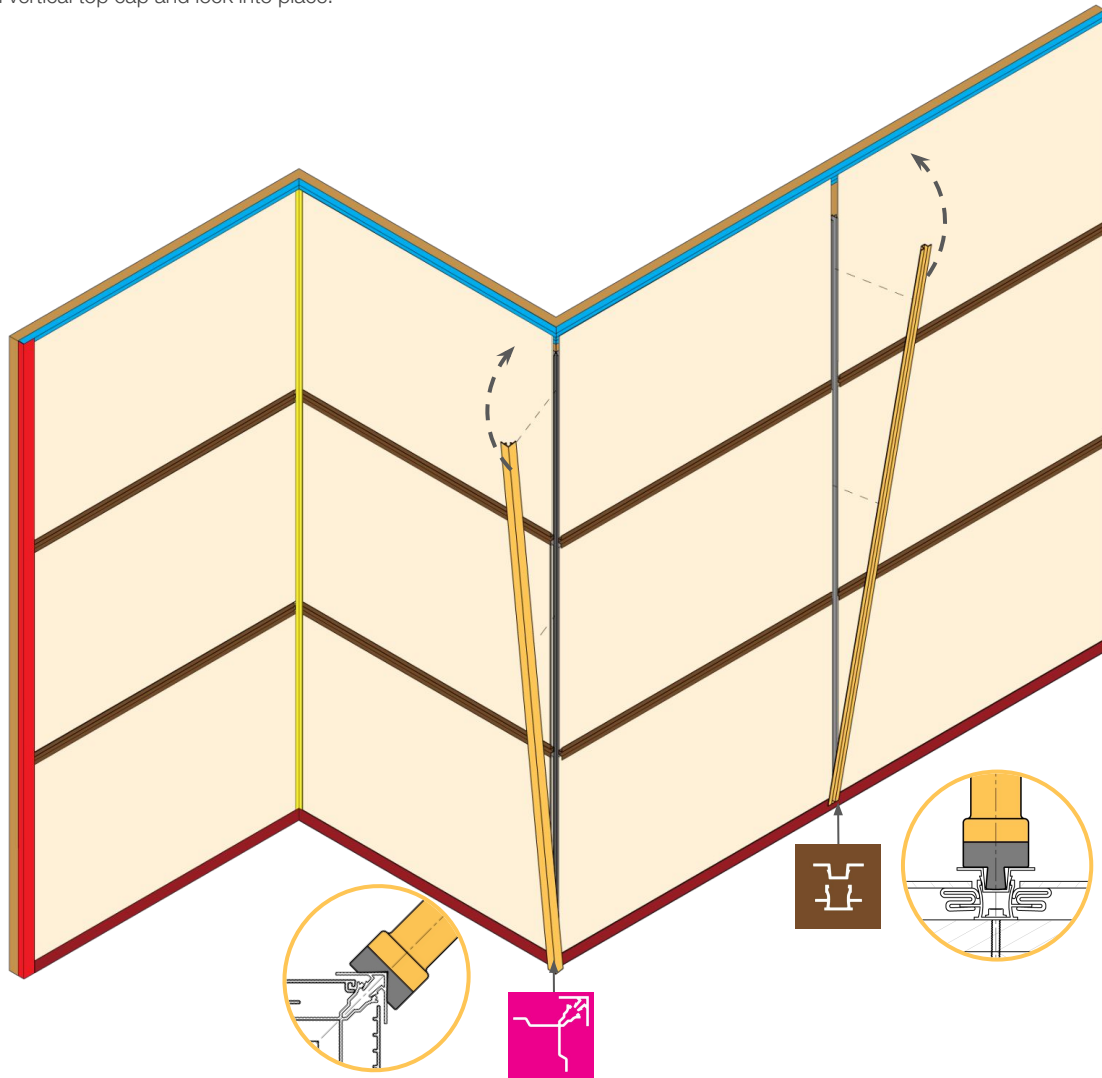

Once two adjacent columns of panels have been installed, the top cap may be installed. Once the top cap is cut to the appropriate length, it should be placed, bottom end first, into place with each end under the tabs of the horizontal End Frames. Once in the correct position it is to be hammered into place with a rubber mallet and AL13® SLED.

If one length of the top cap extrusions is not long enough to span the distance required, it is necessary to use a second piece and butt the two together. Take care in aligning buttjoints so that they share the same back plate.

**Note:** Do not butt two top caps at an intersection where no back plate is present.

**Note:** the Outside Corner Cap needs to be installed with the 2OC SLED and engaged at 45° to the wall.

See the Section 02 for further details.

---

## Panel Install

Wall installation is complete.

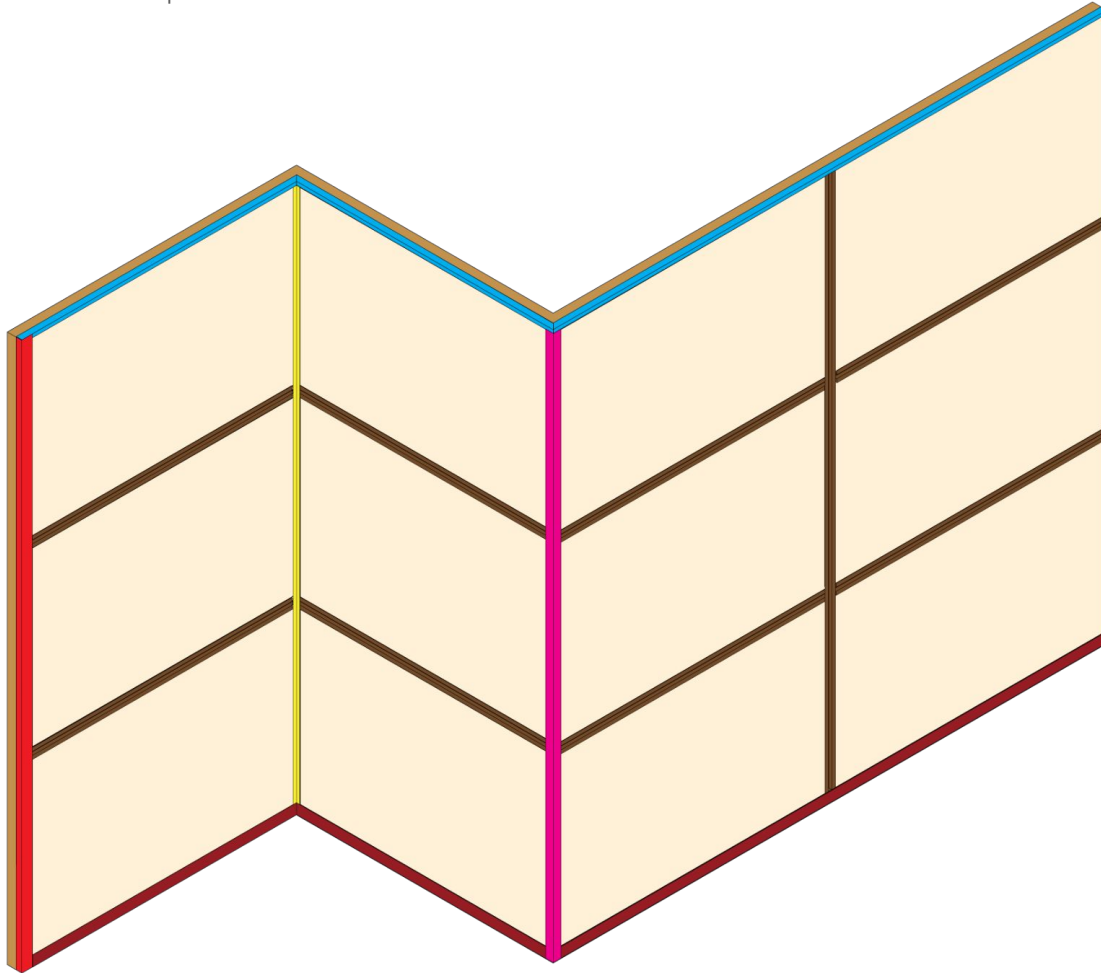

04

## Fascia Installation

---

## Fascia Installation

Fascia installation.

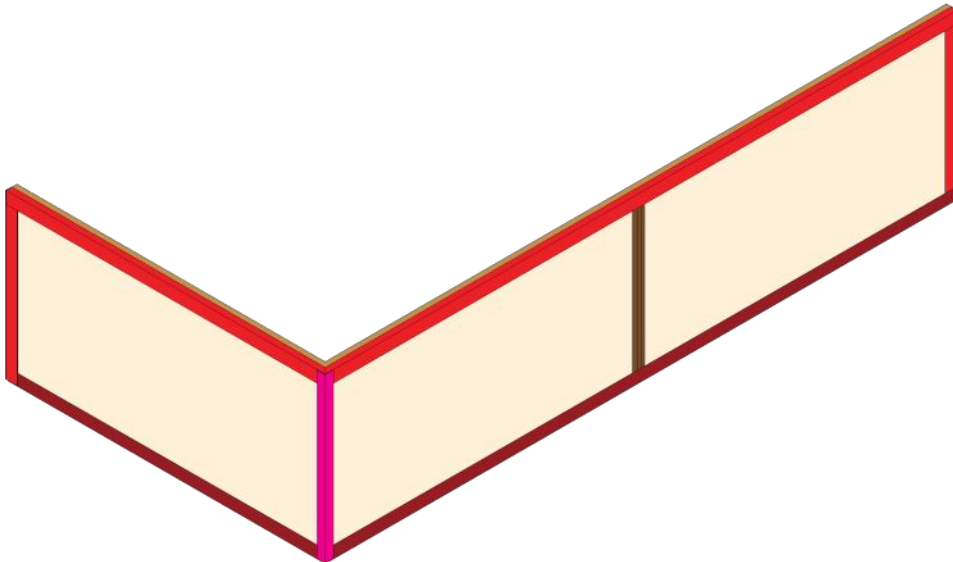

---

The section of the installation guide outlines a basic install on a fascia as illustrated above in its completed form.

The steps in fascia installation are similar to the installation steps outlined in the previous chapter.

Please be sure to have read the General Install and the Pro Tips section first.

---

**IMPORTANT:** The building envelope, which includes a weather barrier and all applicable flashings, must be completed to local building code before any AL13® component is to be laid out or installed.

---

The extrusion colours are based on the **Take-Off Extrusion Legend**; see Section 02 for reference.

## Fascia Installation

Prepare grid layout. Use the **Back Plate, Extended** for the lower fascia edge shared with the soffit. Measure and cut the back plates, allowing for a 2in gap between the horizontal upper and lower extrusions.

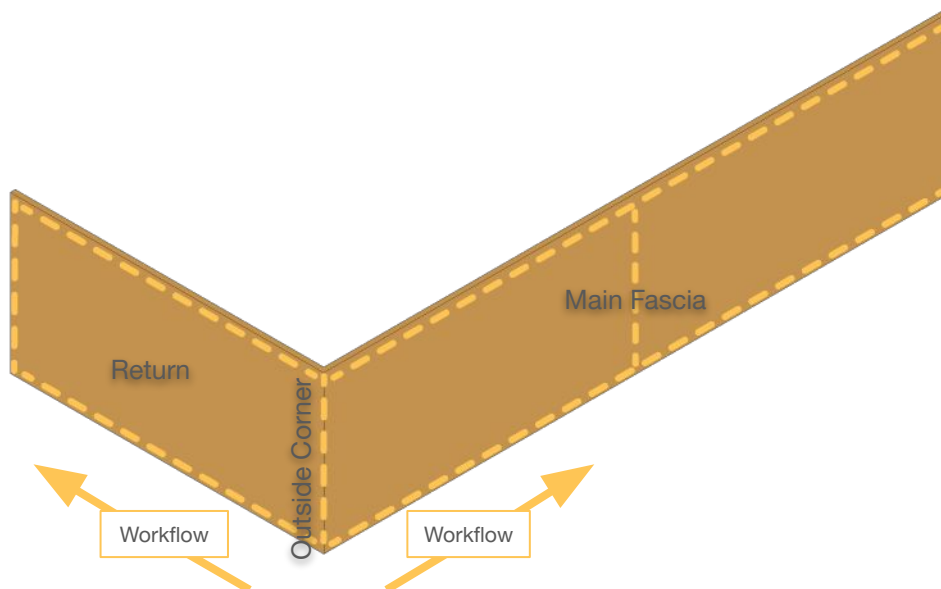

Refer to your building plans to determine the layout.

In this example, the main fascia is one panel across and one panel high; the return fascia is one panel across and one panel high.

The top of the fascia and the end verticals are using a two-piece extrusion assembly.

Using the chosen layout, determine the best suited datum - or starting point - shown here as the lower left corner/outside corner.

Lay out the panel grid using chalk lines (or similar) from the datum point, ensuring that all lines are plumb or level. These lines are to indicate the locations of the extruded frame components that will secure and frame the ACM panel.

Follow the directions of the arrows when considering your workflow.

Also ensure that **two** one-piece extrusions are **NOT** parallel to each other to frame one panel. It is important to have a two-piece extrusion assembly on the opposing side to facilitate panel installation.

## Fascia Installation

Install the perimeter extrusions.

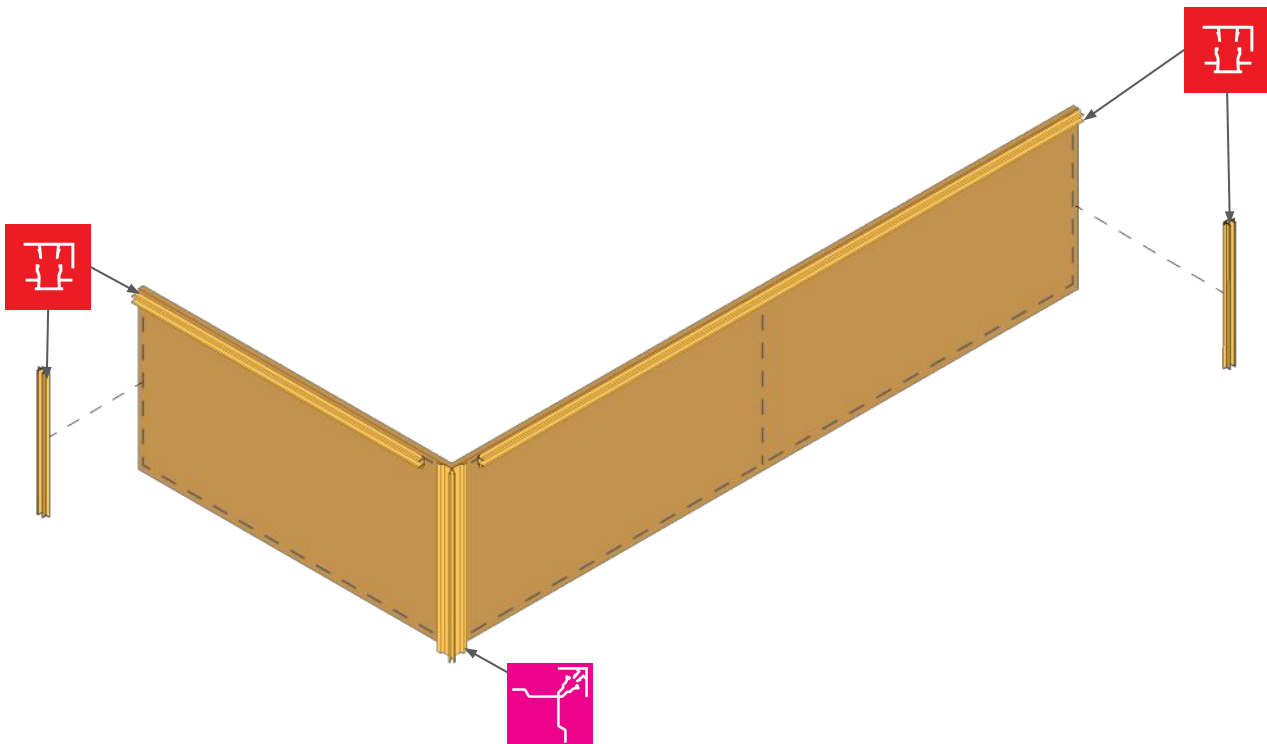

The example assumes a non-AL13 soffit is used. The return fascia is only one panel wide. However, a two-piece outside corner is used in this example.

Only the Two-Piece Outside Corner back plate and Back Plate, Universal are installed prior to finishing the fascia. The corresponding top caps are installed towards the end of installation.

The preferred method to install the extrusion is to fasten the top part first (upper 3"), then the bottom (lower 3"), followed by all fasteners in between. Typical fastener spacing on all extrusions with the Panel system is to be **no greater than 24"** with a **minimum of 2 fasteners per extrusion**. Fastener spacing may be increased, to add additional pull out capacity. Consult the fastener specifications guide to determine fastener type and spacing.

## Fascia Installation

Use the Back Plate, Extended for the lower fascia edge shared with the soffit.

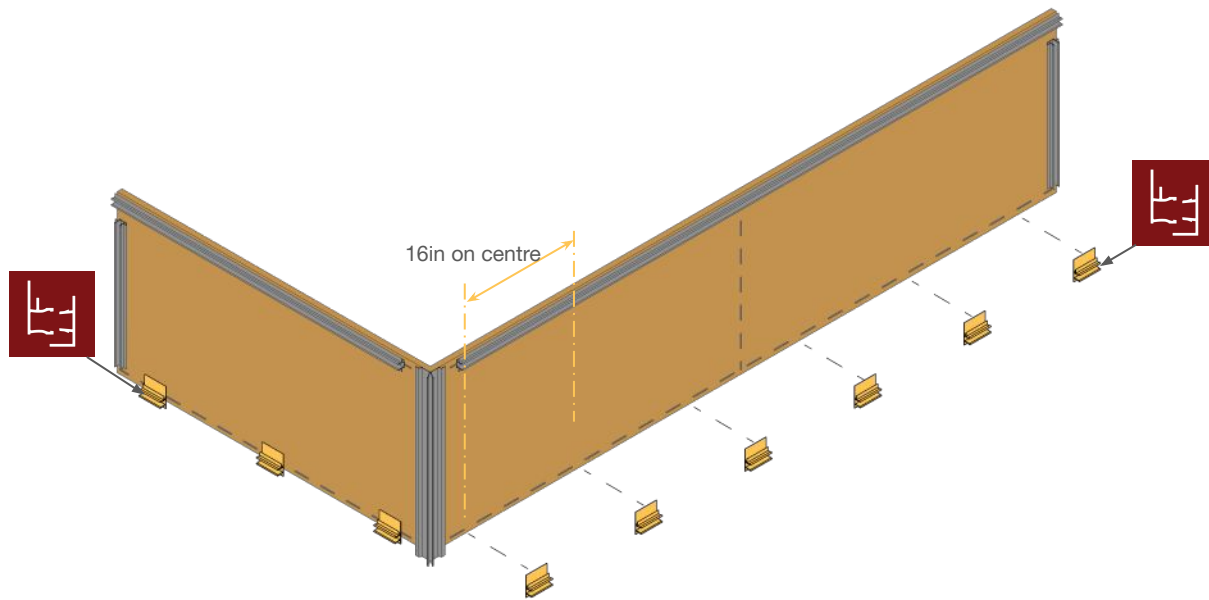

The bottom row comprises segmented Back Plate, Extended sections, cut to a length of 3-1/4in and installed every 16in. This ensures that, at any given horizontal cutaway, only 20 % of the material is attached to the wall to an 80 % open cavity. This provides necessary capillary break and fulfills the rainscreen requirements.

**Note:** If installing on girt, segmenting the back plates is not necessary.

Note the **Back Plate, Extended** is used for the bottom perimeter of the fascia specifically when a non-AL13 material is used for the soffit.

The bottom edge of the Back Plate, Extended can be offset from the fascia edge by up to 1.5in. This provides allowance for the fascia to cover the edge of a non-AL13 soffit.

See the Pro Tips section for details.

It is important to install the segments ensuring they are completely plumb and straight. A level or straight edge may be used to assist with alignment.

If the soffit is either AL13 Panel or Plank, a smooth transition can be made using a Two-Piece Outside Corner.

---

## Fascia Installation

Fasten the vertical back plate.

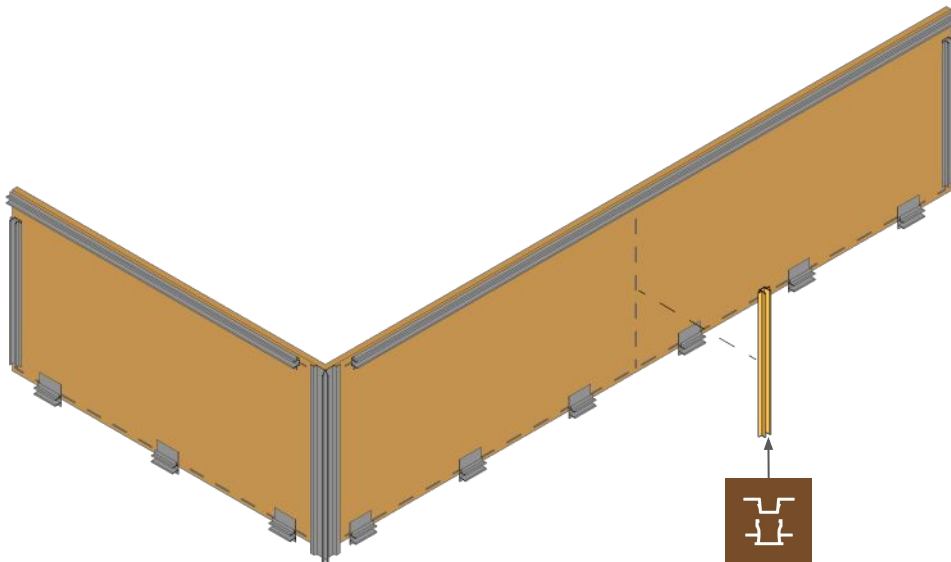

---

Measure and cut the vertical back plate. Allow for approximately 2" gap from horizontal upper and lower extrusions to allow for proper top cap installation.

Begin by fastening the top of the extrusion first (upper 3"), followed by the bottom (lower 3"), then the intermediate fasteners.

**Note:** allow for approximately a 2in gap from the upper and lower horizontal extrusions

Only the Back Plate, Universal is installed at this step. The Reveal Cap is installed towards the end of installation as shown in a subsequent step.

---

## Fascia Installation

Attach the System Clip, Compressible to the back plates.

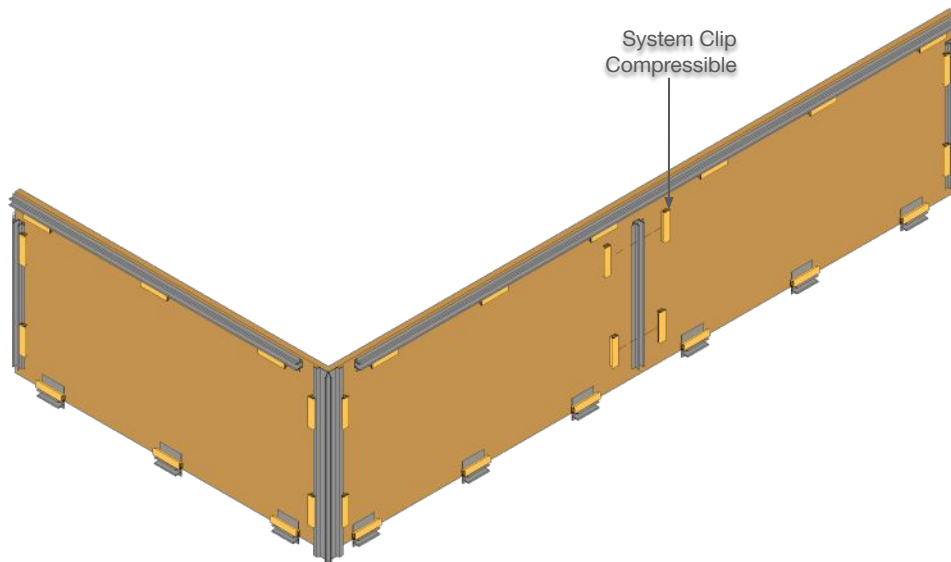

---

Once all required extrusions have been installed, it is time to attach system clips to all the extruded frame components.

System clips act as spacers and are installed with the thin tab pointing towards the wall and the thicker portion facing away from the wall. System clips keep the panels tight to the frame without the need for adjustment.

System clips are to be **attached at a minimum every 16"**, or 1 system clip per tab on the smaller segmented horizontal pieces. Position system clips 3in-4in away from corners and intersections.

System clips are intended to be a firm and secure friction fit. Repeated attempts pulling the clip off and snapping it back on may weaken the integrity of a clip. Once a clip has been snapped in place, it should not be repeatedly taken off and snapped back on. If any clip is found to have been weakened through repetitive use, it should be discarded and a new one used in its place to ensure a secure fit.

## Fascia Installation

Install the lower top caps.

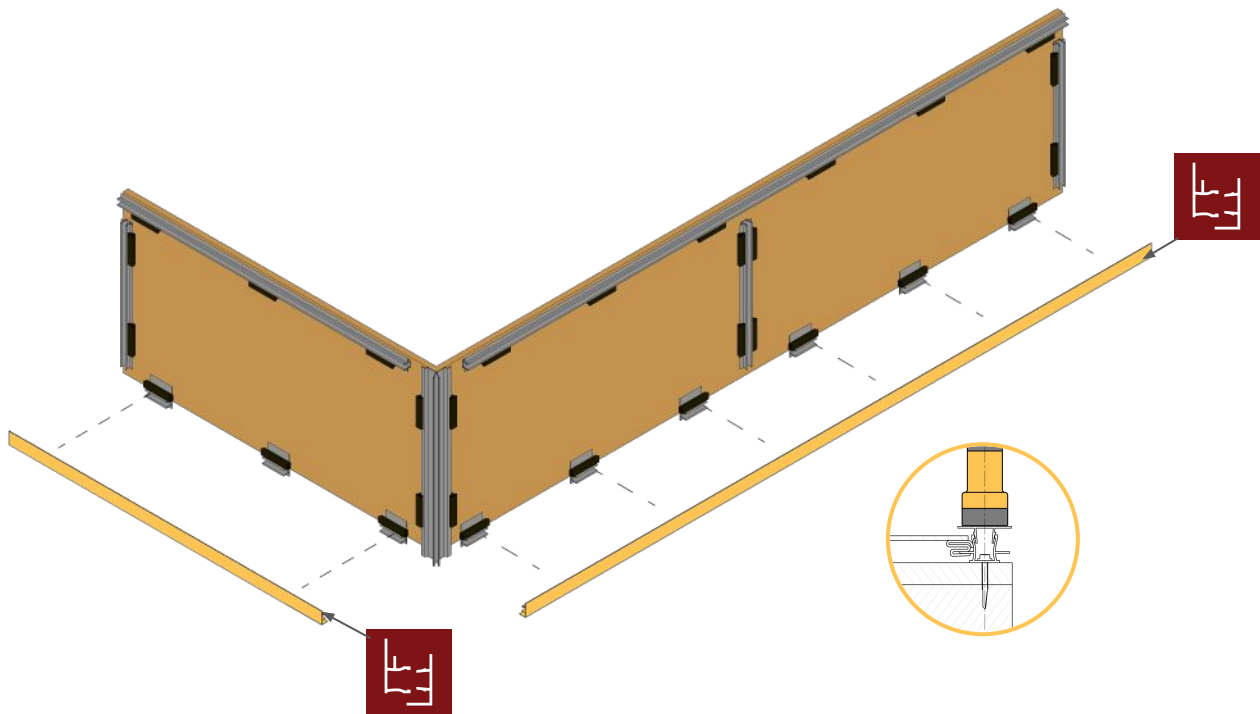

Measure and cut the bottom horizontal top cap. A proper fit will ensure that either end may be tucked into the vertical caps, leaving a minimum 1/16in gap to allow for proper contraction and expansion of the extrusion.

Engage the top cap into the segmented back plates using an **AL13® SLED** with a rubber mallet. It is imperative to only make contact where back plates are present so as not to damage or warp the top cap.



**Caution:** In some installations, more than a full length of a top cap may be required. In this case, ensure that the seam is supported adequately by a back plate.

## Fascia Installation

Measure panel size for fit.

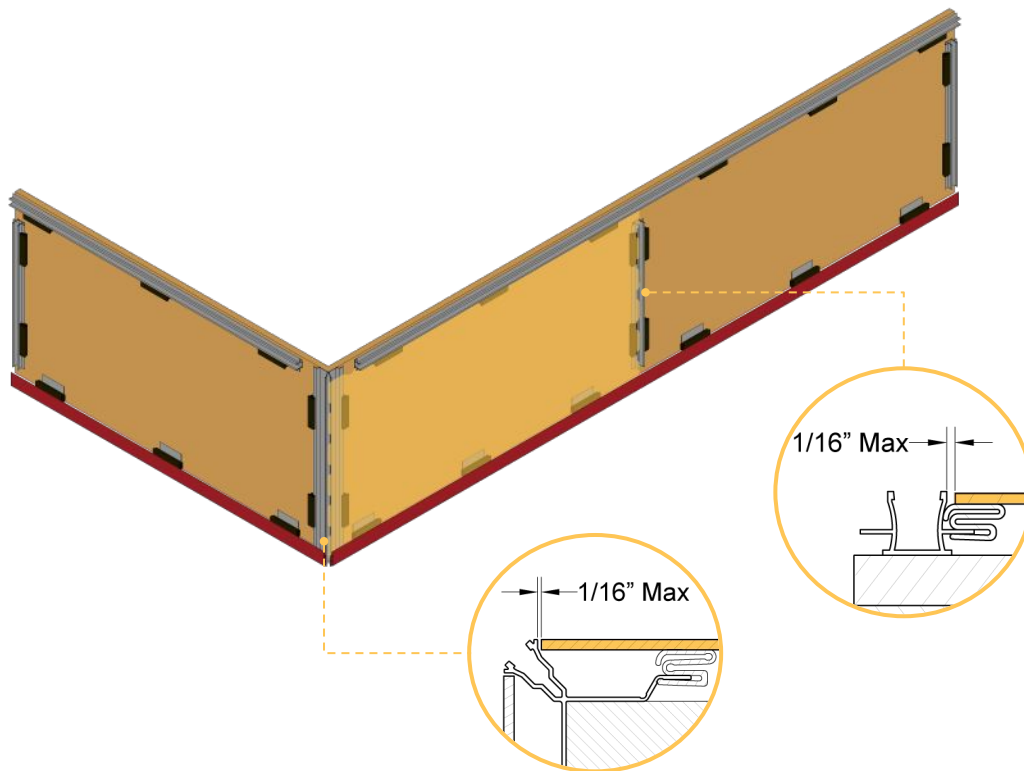

Once a panel is ready to be fit, it may be taken off the stack. **Lift the panel** up off the stack, **then away**; do not drag the panels.

Although the panels have a protective film applied from the factory, reckless panel handling may cause damage to the panel through the wrap. It is recommended that at least two persons carry one sheet.

A panel may need to be cut down if a smaller size from the standard 4ft x 8ft (1220 x 2440 mm) is required. This may be done on a standard circular saw, panel saw or table saw - so long as an AL13® blade is used.

Use a guide to ensure cuts are straight and clean. The appropriate panel fit should account for approximately a 1/16in gap on all sides to allow for expansion and contraction of the metal.

Gloves should be worn to keep the panel clean and to protect hands from sharp edges.

## Fascia Installation

Install the panels.

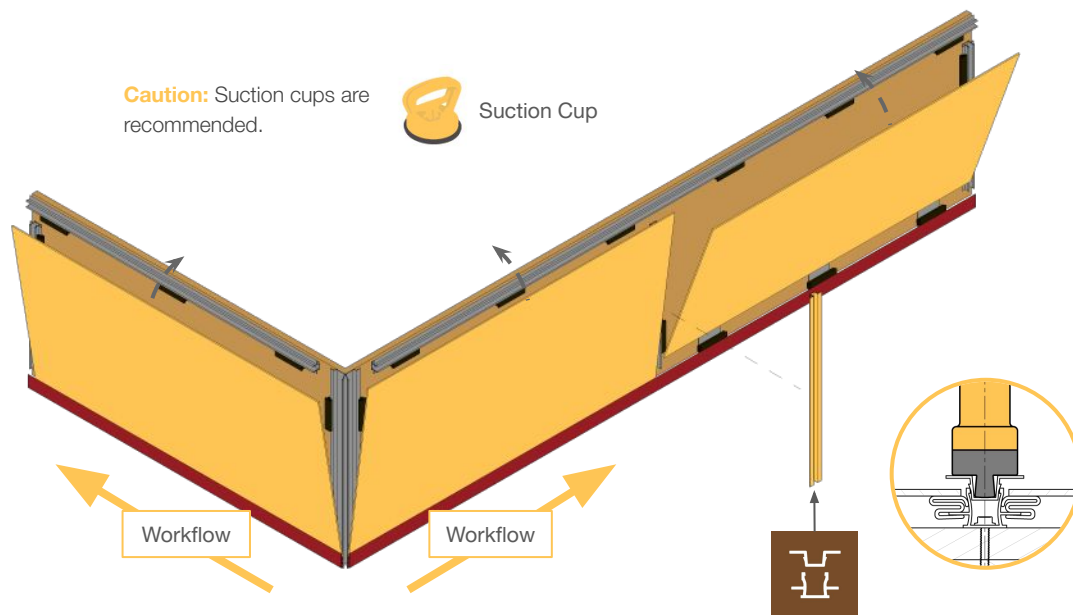

The protective film should be peeled back approximately 1" (25 mm) from the edges, but should remain on the panel otherwise.

Suction cups are recommended for installing panels as they allow for much greater grip and free your hands from a potential pinch hazard.

Position the panel on its long edge, as shown, lift it up and place in position. Ensure the bottom edge is between the tab of the bottom cap and the system clips.

Once the bottom of the panel is seated, rotate the panel into position to double check the fit. The edges should be 1/16in away from the back plate.

Install the panels in the direction of the workflow, following one arrow at a time.

After the panel has been shifted into the correct position, you must securely fasten it in place with a top cap with a rubber mallet and the AL13® SLED.

## Fascia Installation

Install the horizontal upper caps.

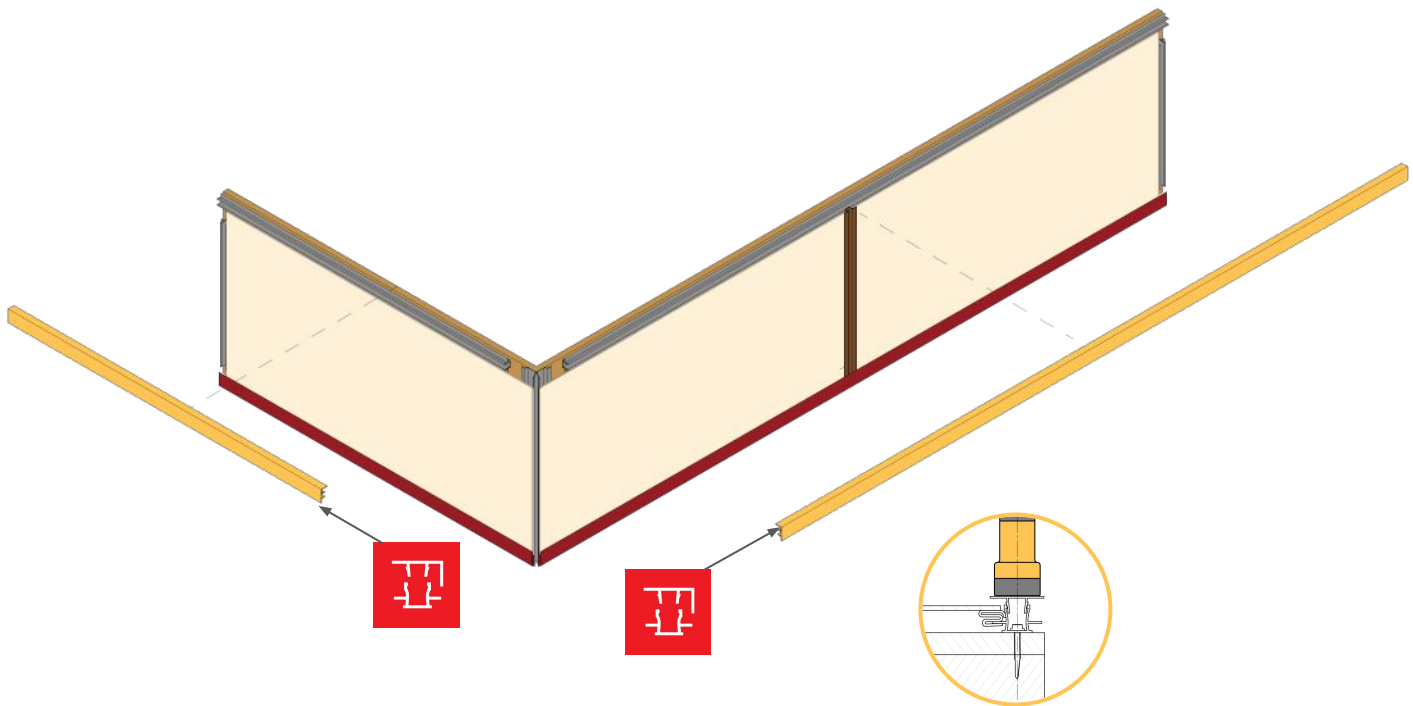

Once the horizontal upper cap is cut to the appropriate length, it may be engaged with a rubber mallet and the AL13® SLED.

Be cautious to only impact the top cap where a back plate is present to prevent any deformation of the frame components.

If one length of the top cap extrusions is not long enough to span the distance required, it is necessary to use a second piece and butt the two together. Take care in aligning buttjoints so that they share the same back plate.



**Note:** Do not butt two top caps at an intersection where no back plate is present.

## Fascia Installation

Install the vertical caps.

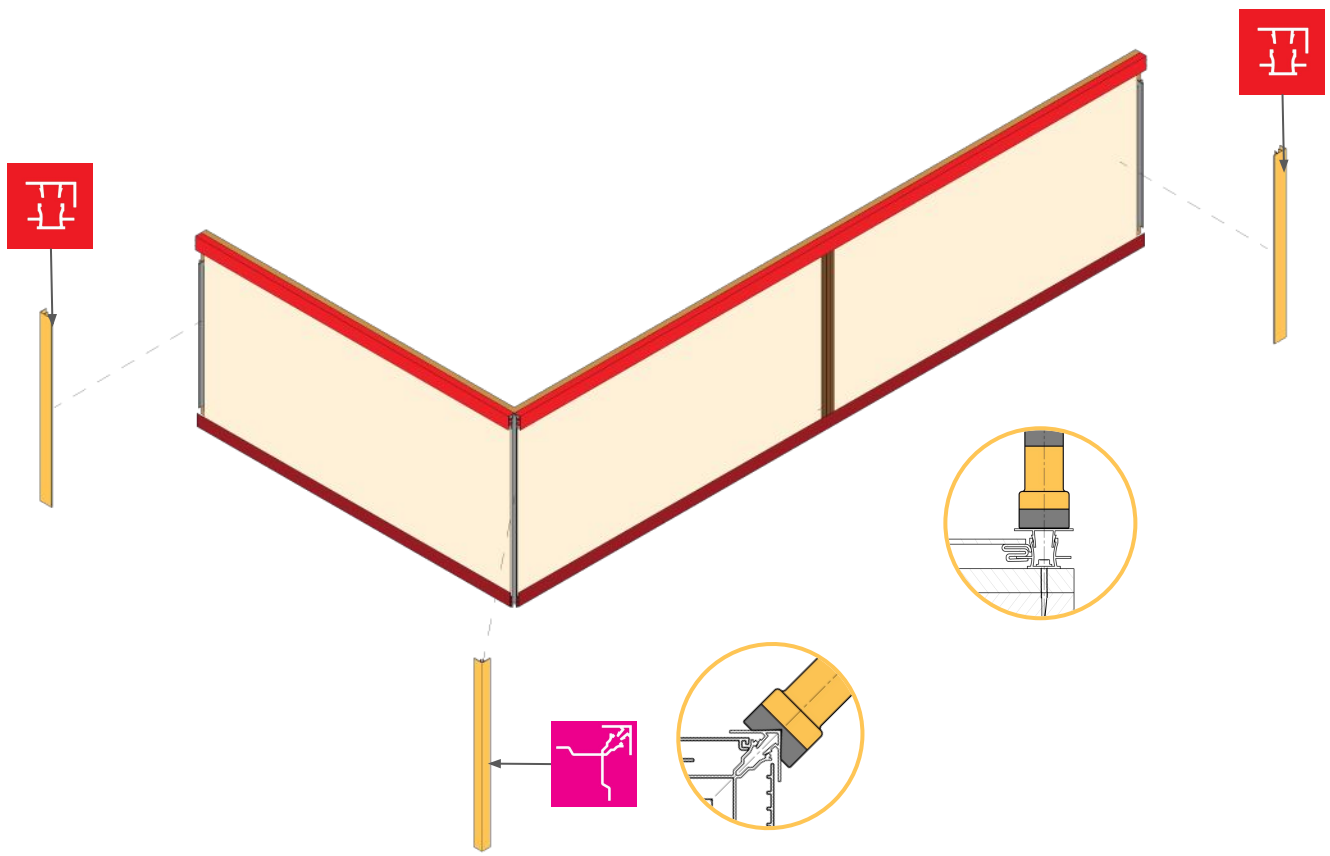

Once the vertical caps are cut to the appropriate length, it may be engaged with a rubber mallet and the appropriate AL13® SLED.

---

## Fascia Installation

Installation is complete.

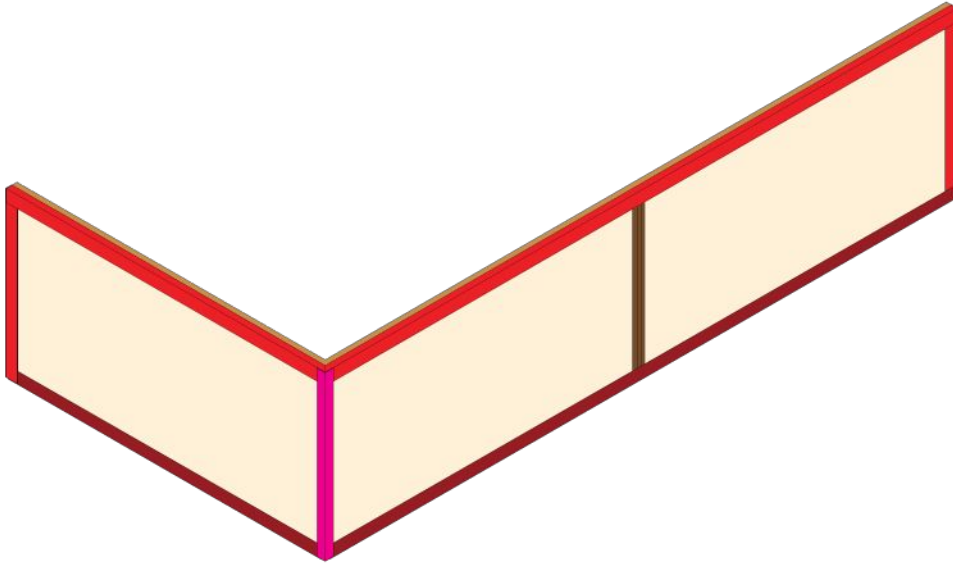

**05**

## **Fascia Installation Alternate**

---

## Fascia Installation

Fascia installation.

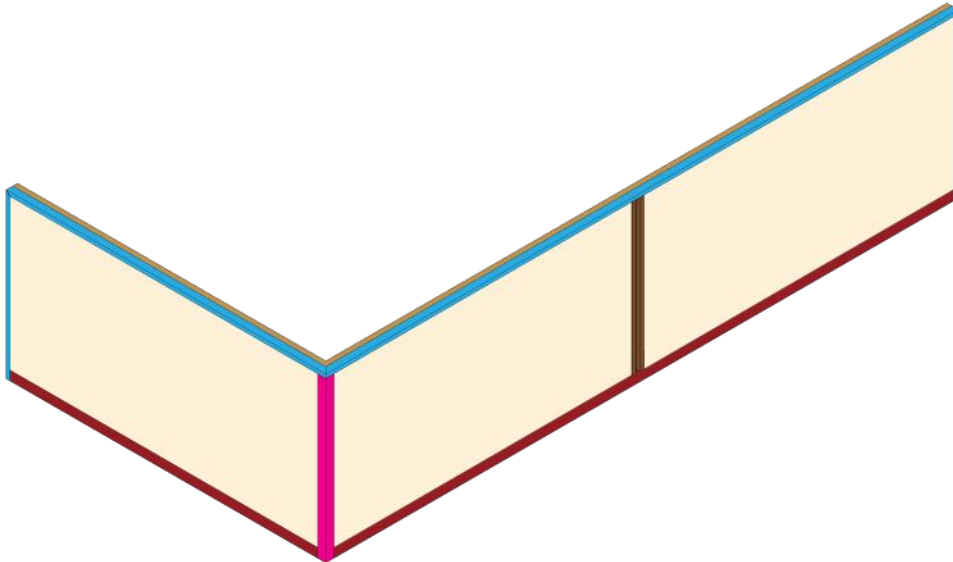

---

The section of the installation guide outlines a basic install on a fascia as illustrated above in its completed form.

The steps in fascia installation are similar to the installation steps outlined in the previous chapter.

Please be sure to have read the General Install and the Pro Tips section first.

---

**IMPORTANT:** The building envelope, which includes a weather barrier and all applicable flashings, must be completed to local building code before any AL13® component is to be laid out or installed.

---

The extrusion colours are based on the **Take-Off Extrusion Legend**; see Section 02 for reference.

## Fascia Installation

Prepare grid layout. Use the **Back Plate, Extended** for the lower fascia edge shared with the soffit. Measure and cut the back plates, allowing for a 2in gap between the horizontal upper and lower extrusions.

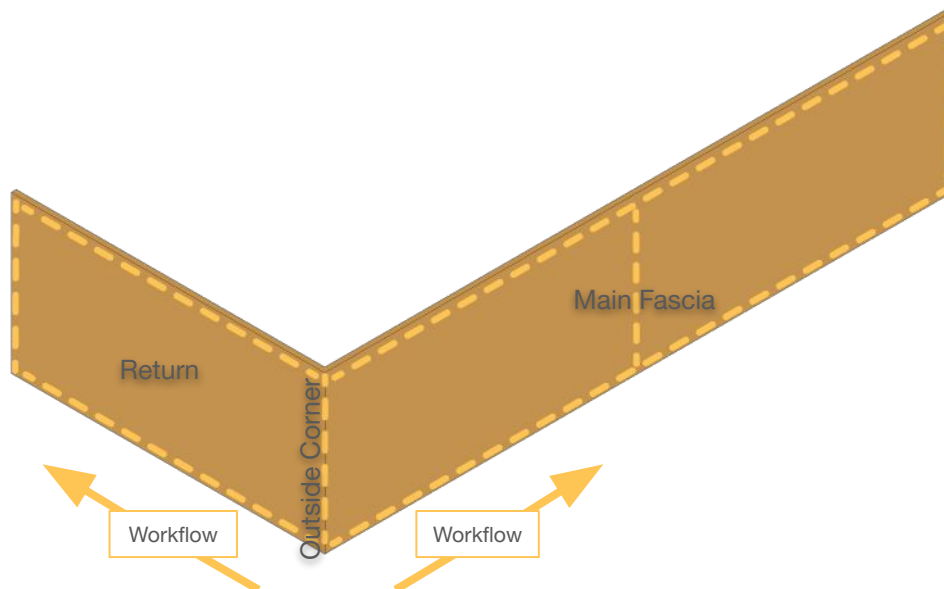

Refer to your building plans to determine the layout.

In this example, the main fascia is one panel across and one panel high; the return fascia is one panel across and one panel high.

The top of the fascia and the end verticals are using an End Frame.

Using the chosen layout, determine the best suited datum - or starting point - shown here as the lower left corner/outside corner.

Lay out the panel grid using chalk lines (or similar) from the datum point, ensuring that all lines are plumb or level. These lines are to indicate the locations of the extruded frame components that will secure and frame the ACM panel.

Follow the directions of the arrows when considering your workflow.

Also ensure that **two** one-piece extrusions are **NOT** parallel to each other to frame one panel. It is important to have a two-piece extrusion assembly on the opposing side to facilitate panel installation.

## Fascia Installation - Alternate

Install the End Frames.

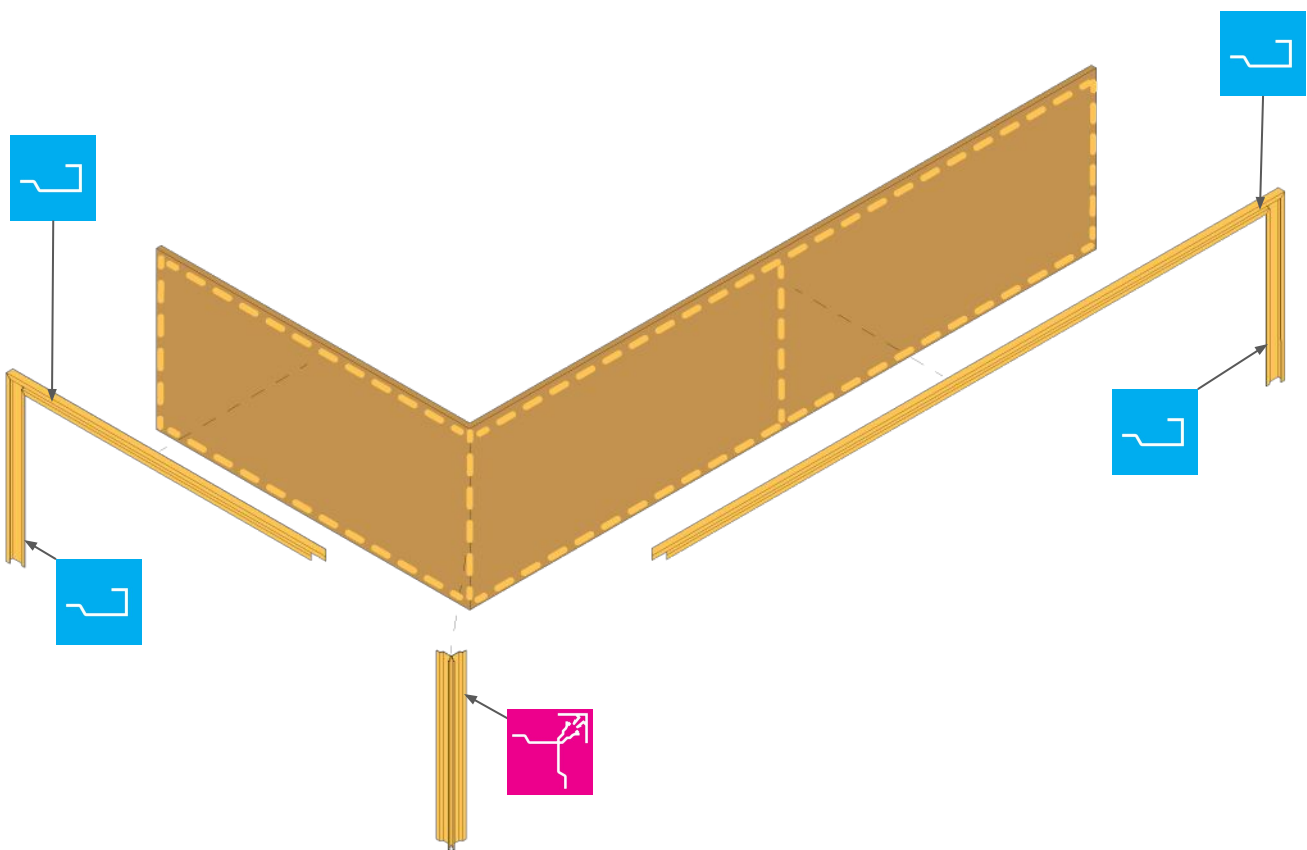

The example assumes a non-AL13 soffit is used. The return fascia is only one panel wide. A two-piece outside corner is necessary in this example.

Only the Two-Piece Outside Corner back plate is installed prior to finishing the fascia. The corresponding top cap is installed towards the end of installation covered in a subsequent step.

The preferred method to install the extrusion is to fasten the top part first (upper 3"), then the bottom (lower 3"), followed by all fasteners in between. Typical fastener spacing on all extrusions with the Panel system is to be **no greater than 24"** with a **minimum of 2 fasteners per extrusion**. Fastener spacing may be increased, to add additional pull out capacity. Consult the fastener specifications guide to determine fastener type and spacing.

## Fascia Installation - Alternate

Prepare grid layout. Use the **Back Plate, Extended** for the lower fascia edge shared with the soffit. Measure and cut the back plates, allowing for a 2in gap between the horizontal upper and lower extrusions.

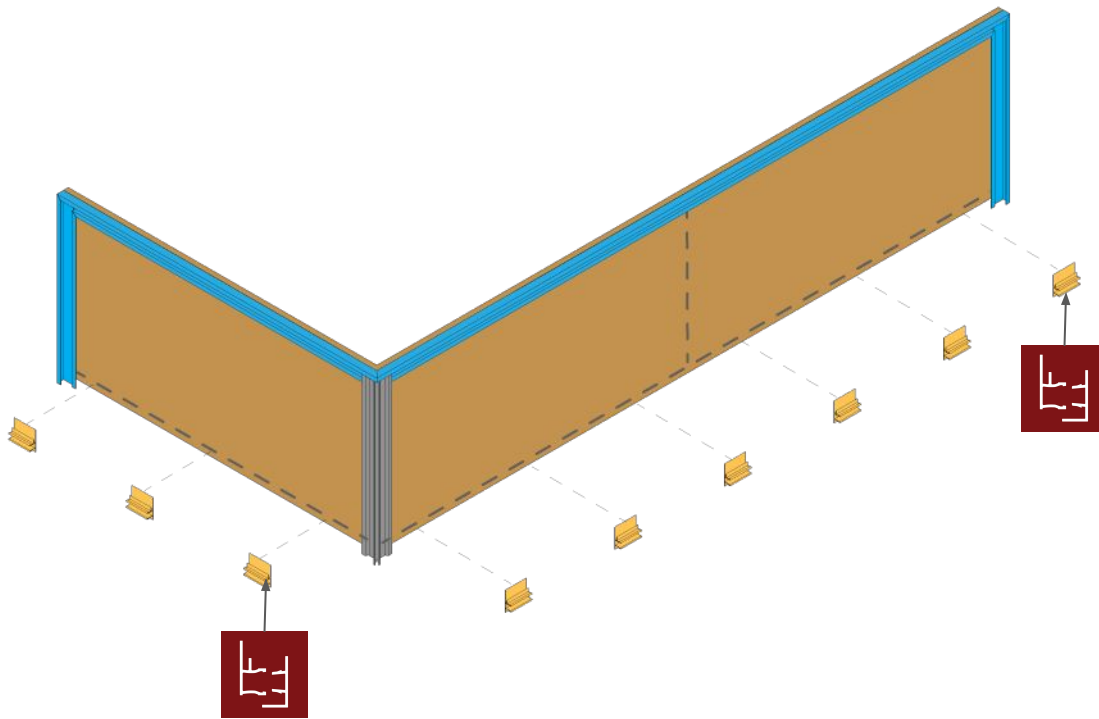

The bottom row comprises segmented Back Plate, Extended sections, cut to a length of 3-1/4in and installed every 16in. This ensures that, at any given horizontal cutaway, only 20 % of the material is attached to the wall to an 80 % open cavity. This provides necessary capillary break and fulfills the rainscreen requirements.

**Note:** If installing on girt, segmenting the back plates is not necessary.

Note the **Back Plate, Extended** is used for the bottom perimeter of the fascia specifically when a non-AL13 material is used for the soffit.

The bottom edge of the Back Plate, Extended can be offset from the fascia edge by up to 1.5in. This provides allowance for the fascia to cover the edge of a non-AL13 soffit.

See the Pro Tips section for details.

It is important to install the segments ensuring they are completely plumb and straight. A level or straight edge may be used to assist with alignment.

If the soffit is either AL13 Panel or Plank, a smooth transition can be made using a Two-Piece Outside Corner.

## Fascia Installation - Alternate

Fasten the vertical back plate.

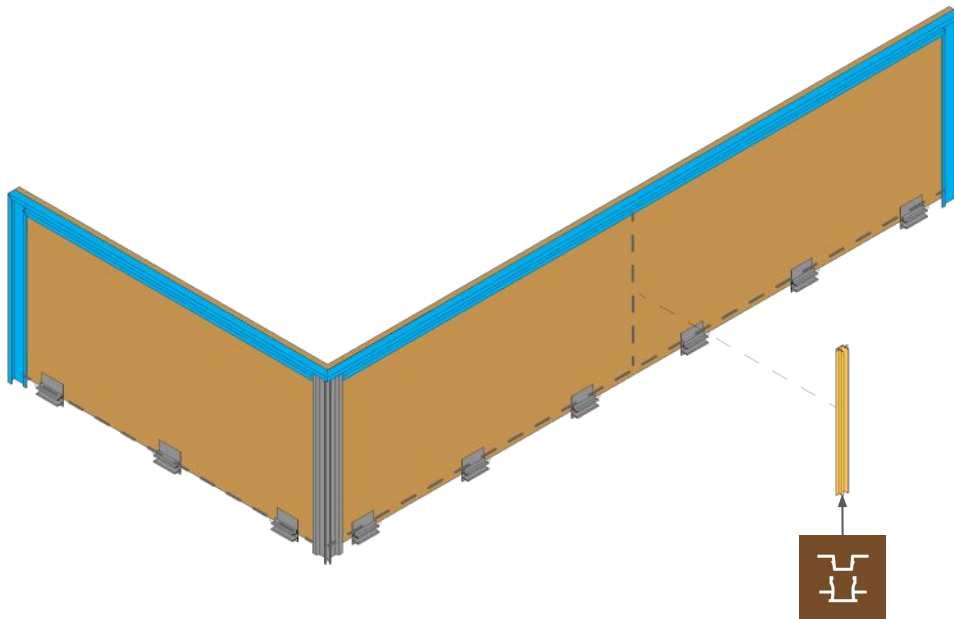

Measure and cut the vertical back plate. Allow for approximately 2" gap from horizontal upper and lower extrusions to allow for proper top cap installation.

Begin by fastening the top of the extrusion first (upper 3"), followed by the bottom (lower 3"), then the intermediate fasteners.

**Note:** allow for approximately a 2in gap from the upper and lower horizontal extrusions

Only the Back Plate, Universal is installed at this step. The Reveal Cap is installed towards the end of installation as shown in a subsequent step.

## Fascia Installation - Alternate

Install the System Clip, Compressible.

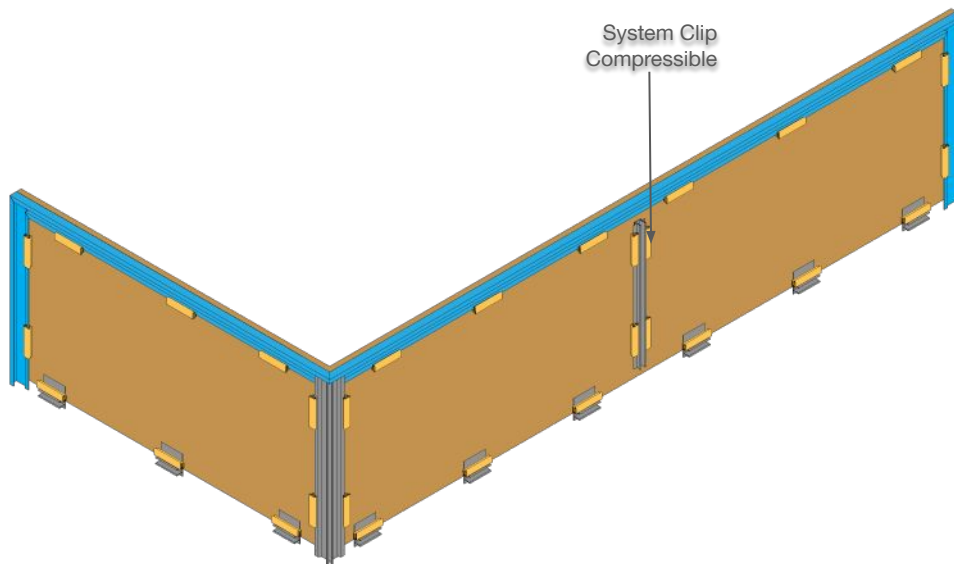

Once all required extrusions have been installed, it is time to attach system clips to all the extruded frame components.

System clips act as spacers and are installed with the thin tab pointing towards the wall and the thicker portion facing away from the wall. System clips keep the panels tight to the frame without the need for adjustment.

System clips are to be **attached at a minimum every 16"**, or 1 system clip per tab on the smaller segmented horizontal pieces. Position system clips 3in-4in away from corners and intersections.

System clips are intended to be a firm and secure friction fit. Repeated attempts pulling the clip off and snapping it back on may weaken the integrity of a clip. Once a clip has been snapped in place, it should not be repeatedly taken off and snapped back on. If any clip is found to have been weakened through repetitive use, it should be discarded and a new one used in its place to ensure a secure fit.

## Fascia Installation - Alternate

Measure Panel size for fit.

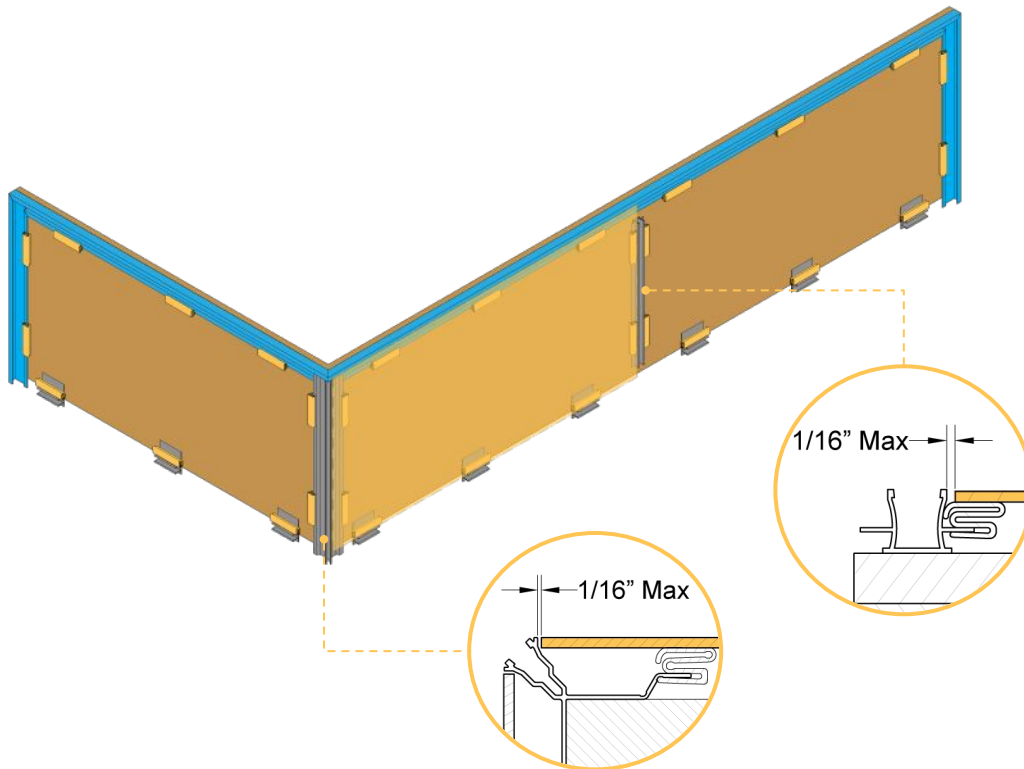

Once a panel is ready to be fit, it may be taken off the stack. **Lift the panel** up off the stack, **then away**; do not drag the panels.

Although the panels have a protective film applied from the factory, reckless panel handling may cause damage to the panel through the wrap. It is recommended that at least two persons carry one sheet.

A panel may need to be cut down if a smaller size from the standard 4ft x 8ft (1220 x 2440 mm) is required. This may be done on a standard circular saw, panel saw or table saw - so long as an AL13® blade is used.

Use a guide to ensure cuts are straight and clean. The appropriate panel fit should account for approximately a 1/16in gap on all sides to allow for expansion and contraction of the metal.

Gloves should be worn to keep the panel clean and to protect hands from sharp edges.

## Fascia Installation - Alternate

Install the Panels.

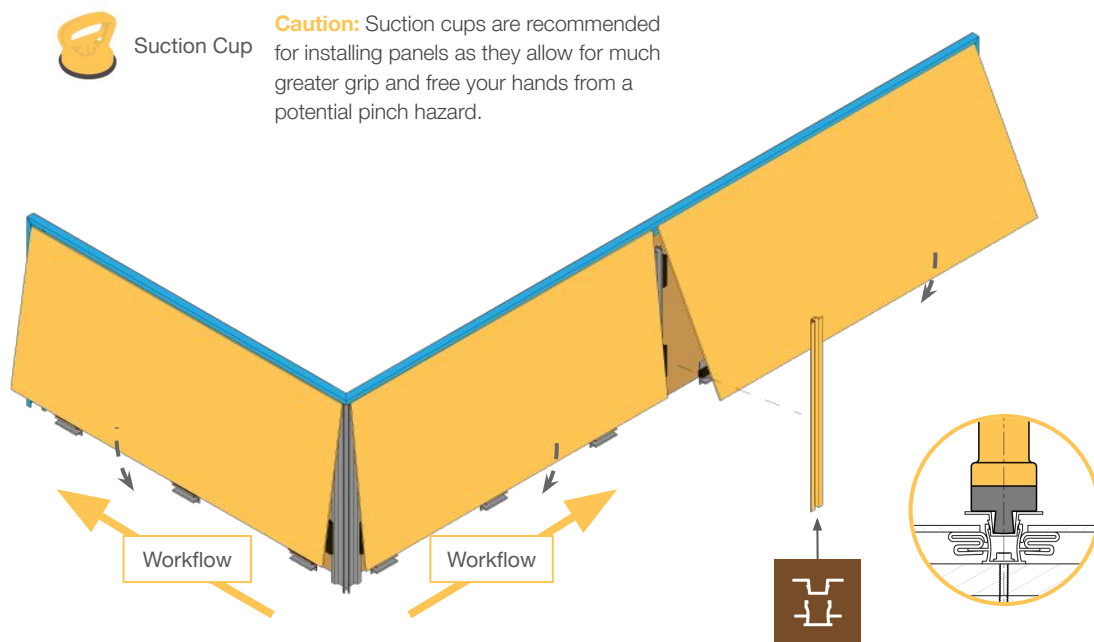

Suction Cup

**Caution:** Suction cups are recommended for installing panels as they allow for much greater grip and free your hands from a potential pinch hazard.

The protective film should be peeled back approximately 1" (25 mm) from the edges, but should remain on the panel otherwise.

Suction cups are recommended for installing panels as they allow for much greater grip and free your hands from a potential pinch hazard.

Position the panel on its long edge, as shown, lift it up and place in position. Ensure the bottom edge is between the tab of the bottom cap and the system clips.

Once the bottom of the panel is seated, rotate the panel into position to double check the fit. The edges should be 1/16in away from the back plate.

Install the panels in the direction of the workflow, following one arrow at a time.

After the panel has been shifted into the correct position, you must securely fasten it in place with a top cap with a rubber mallet and the AL13® SLED.

## Fascia Installation - Alternate

Install the horizontal lower caps and the vertical outside corner cap.

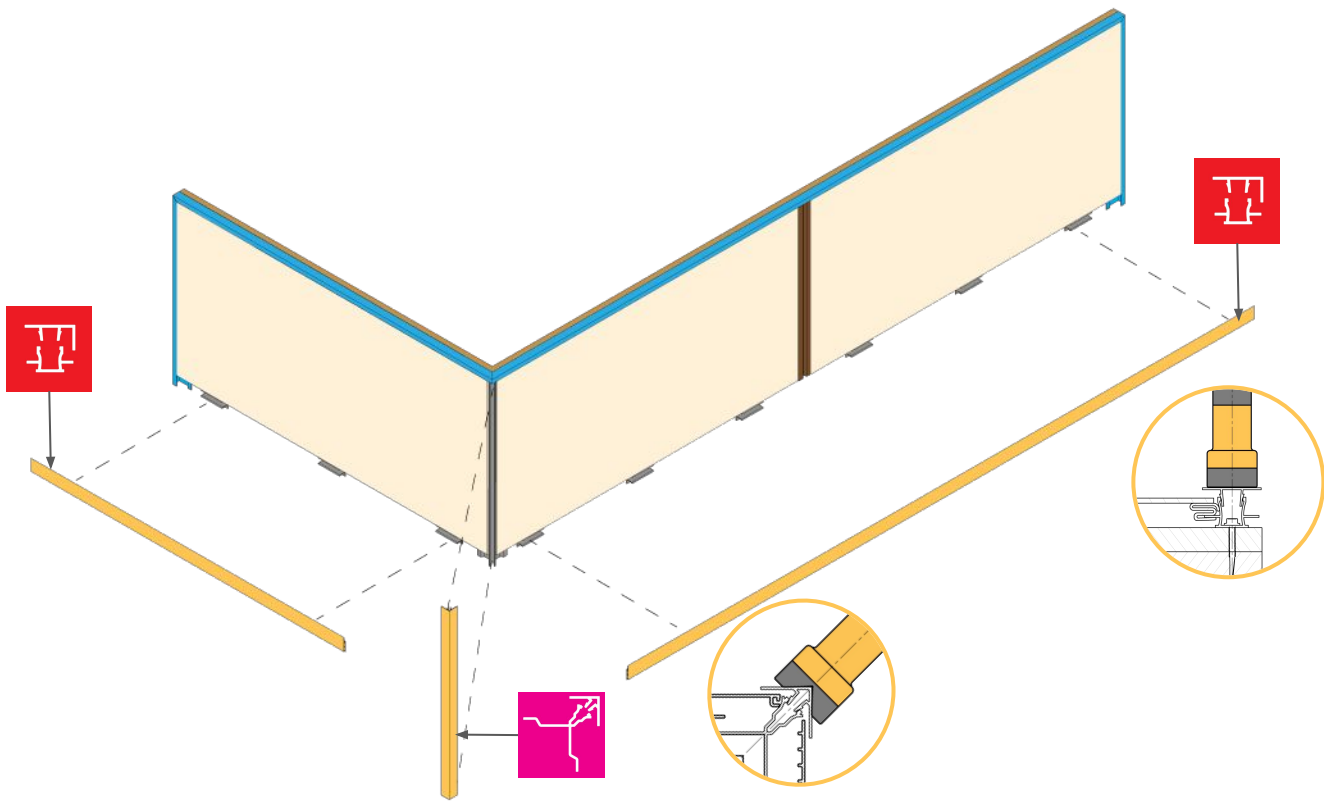

Once the horizontal lower cap is cut to the appropriate length, it may be engaged with a rubber mallet and the AL13® SLED.

Be cautious to only impact the top cap where a back plate is present to prevent any deformation of the frame components.

If one length of the top cap extrusions is not long enough to span the distance required, it is necessary to use a second piece and butt the two together. Take care in aligning buttjoints so that they share the same back plate.

Once the Two-piece outside corner cap is cut to the appropriate length, it may be engaged with a rubber mallet and the appropriate AL13® Corner SLED.

---

## Fascia Installation - Alternate

Installation is complete.

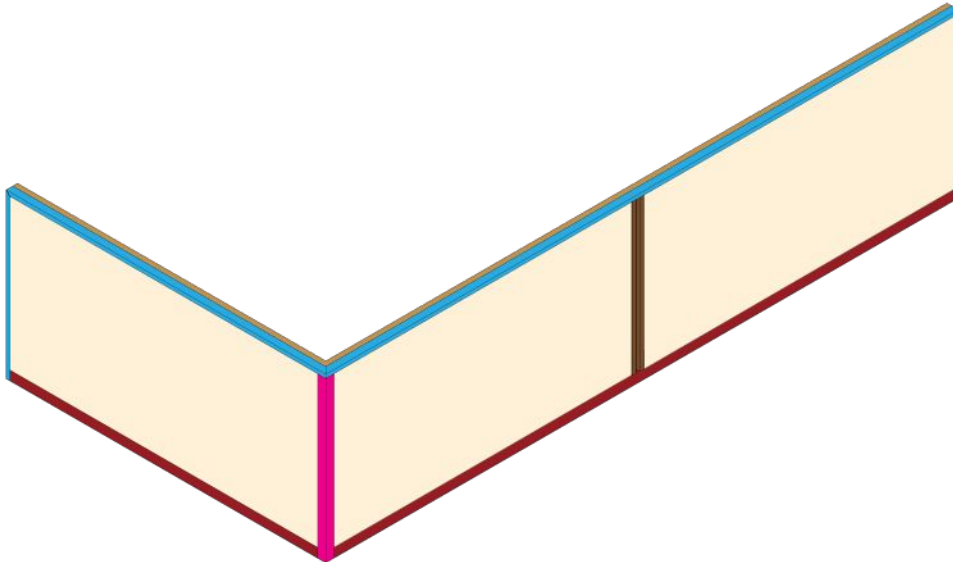

06

## Protective Film Removal

---

## Removal of Protective Film

Finishing and inspection.



ACM Panel Protective Plastic Film

---

Once the install is complete, work from the top down to remove the protective plastic film and clean the panels as required. Take note of any installation flaws and ensure all top caps are fully hammered into place.

***Protective film must be removed once install is complete.***